

GRILL CABIN 9.2 with SLOPING walls

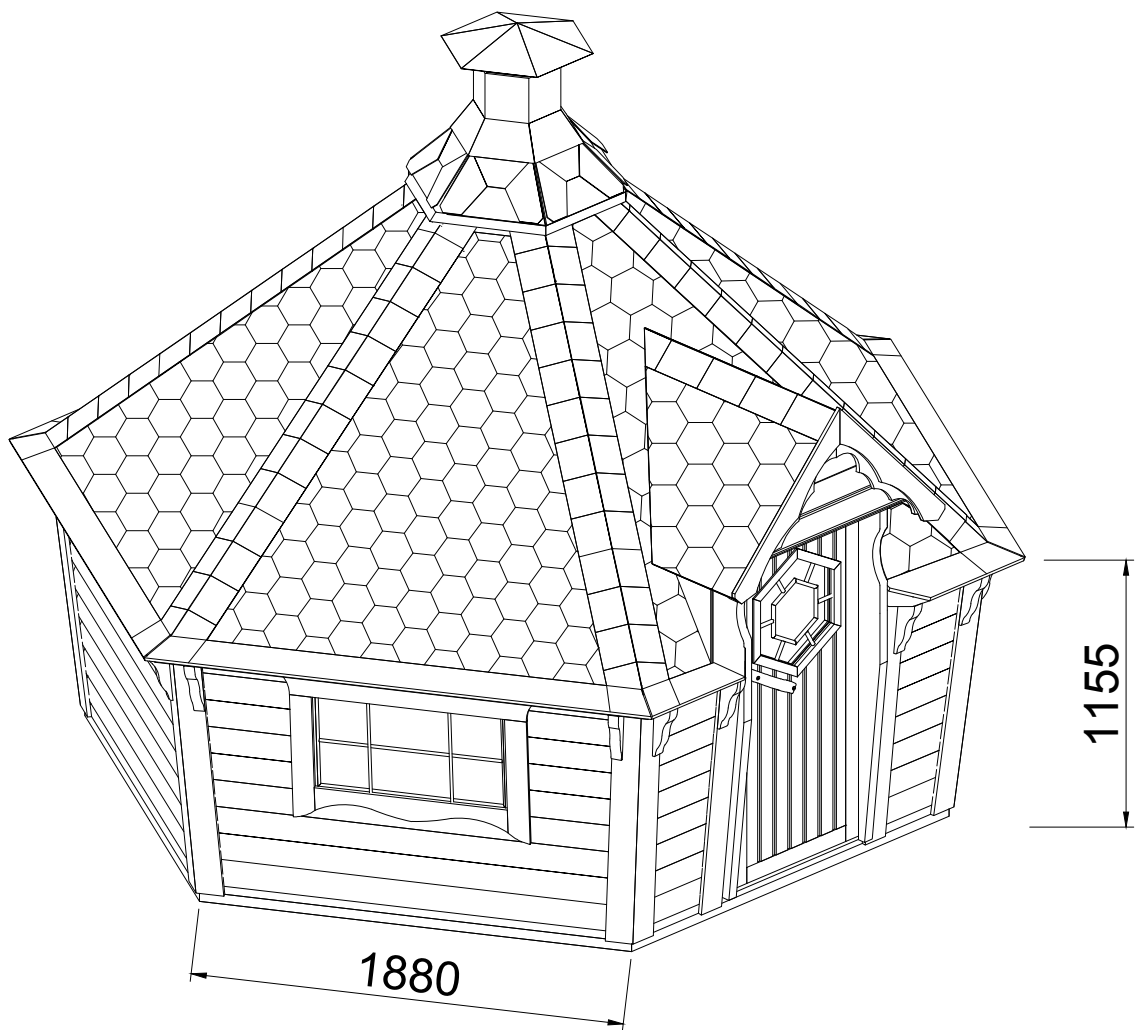

Stages of assembly

Grill / Camping

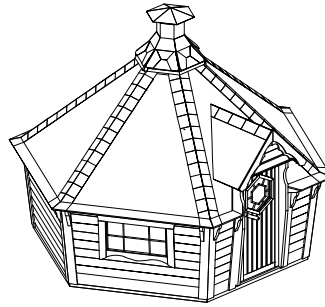

1. Step: wood ring

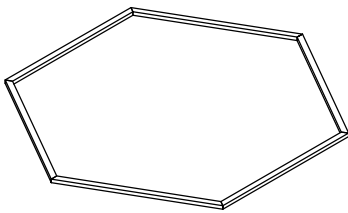

2. Step: walls

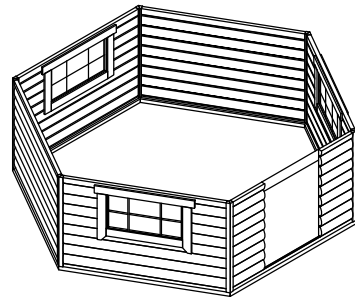

3. Step: decoration (support)

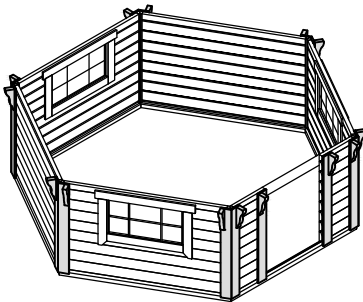

4. Step: roof support ring

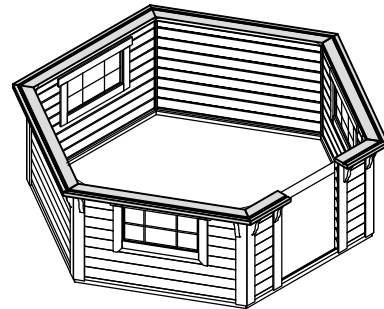

5. Step: floors

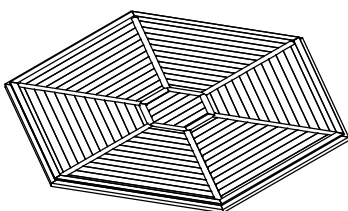

6. Step: roof

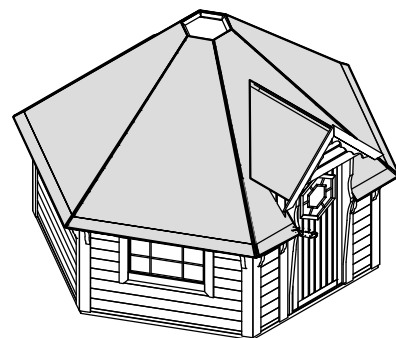

Grill cabin 9.2 with sloping walls FOUNDATION

It is very important to have a proper foundation.

Therefore we recommend making the foundation according to the sketches here. First of all, foundation must be prepared according to the landscape and ground conditions.

The foundation under the product must be prepared specially, it must be homogeneous, tight and equal. It must be ensured that it will not change its properties. We recommend using concrete foundation. Before installation of product, we recommend to make hydro isolation of foundation.

Consult a local qualified builder or an engineer to prepare a proper foundation, which fits to your location.

Due to improper foundation, cracks in the structures may occur. Due to uneven product seating, the geometric shape of the product may change, which can result in door / window twist, or/and gap may appear. And in the worst case product's collapse.

If you do not follow recommendation, product will lose its warranty.

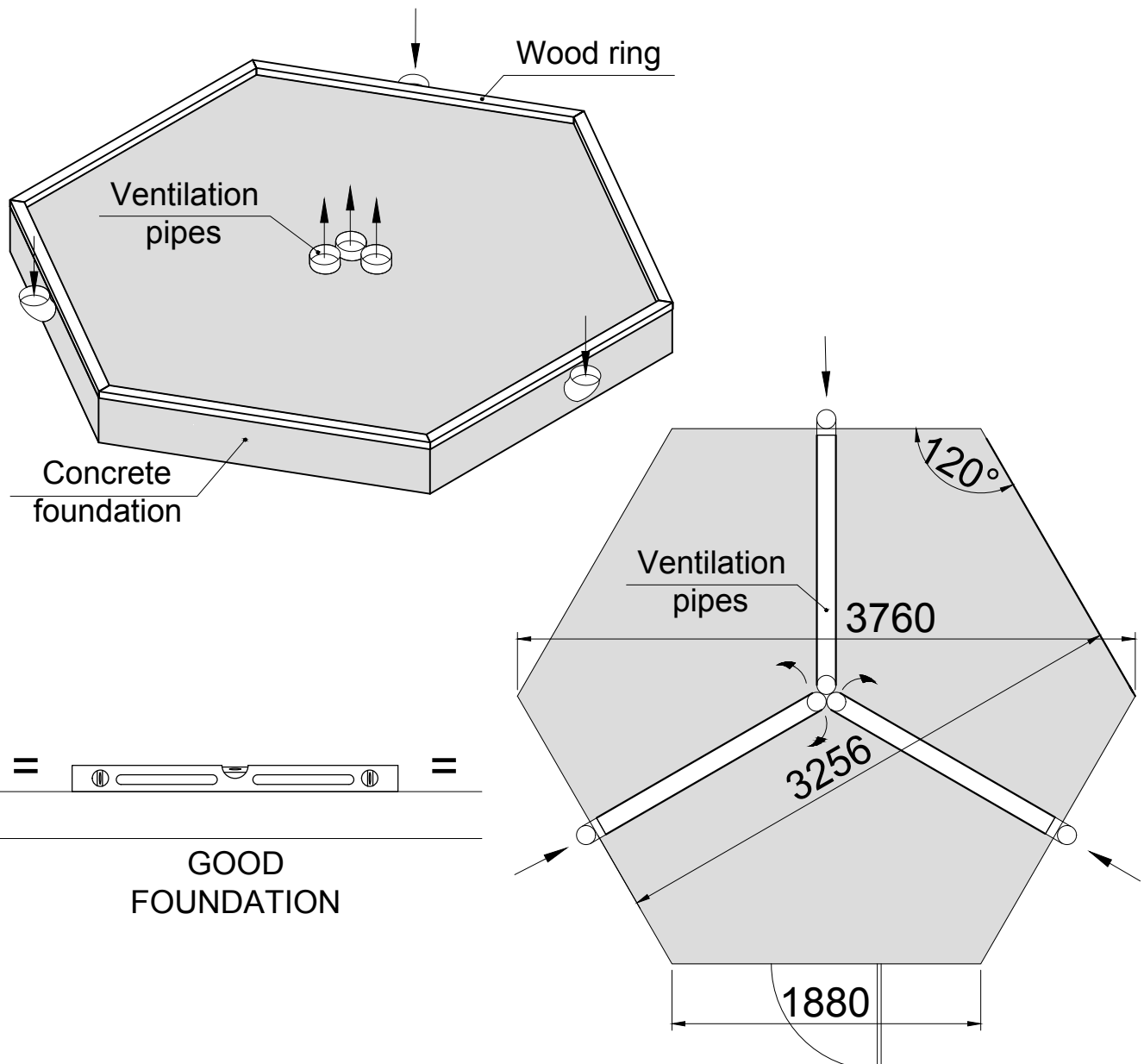

1. Grill cabin 9.2 with sloping walls
WOOD RING - FOUNDATION

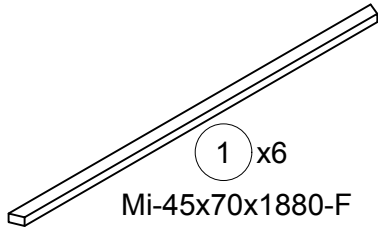
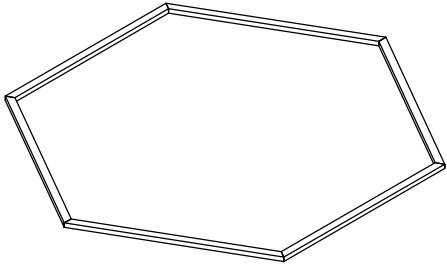

1 x6

2 x12

Mi-45x70x1880-F

T-GC-5x100

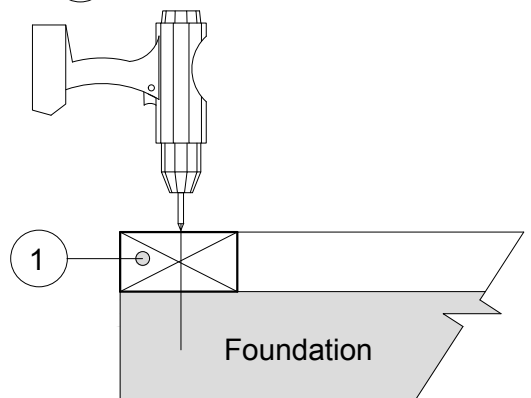
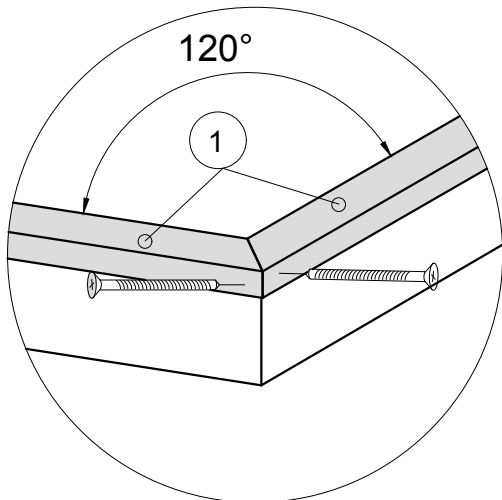
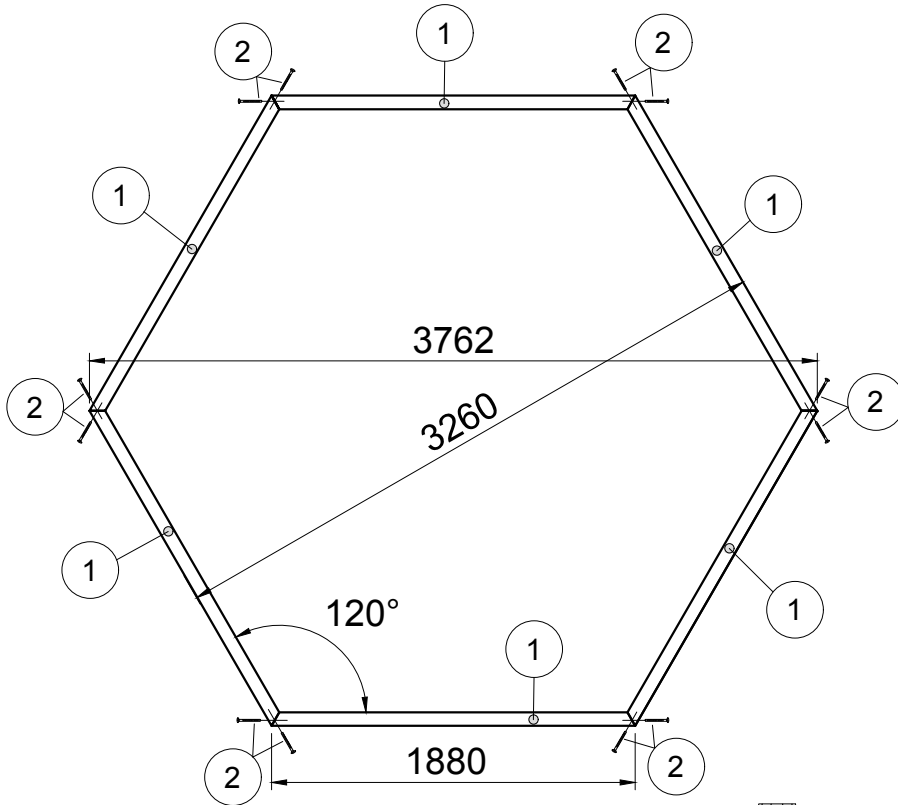

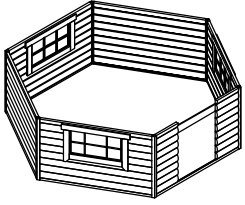

2. Grill cabin 9.2 with sloping walls WALLS CONNECTION

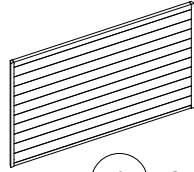

1 x2

GRp9.2-S-1161x2020

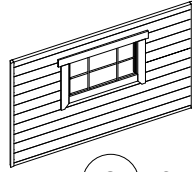

2 x3

GRp9.2-SL-1161x2020

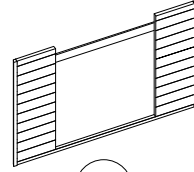

3 x1

GRp9.2-SD-1161x2020



4 x48

T-GC-5x100

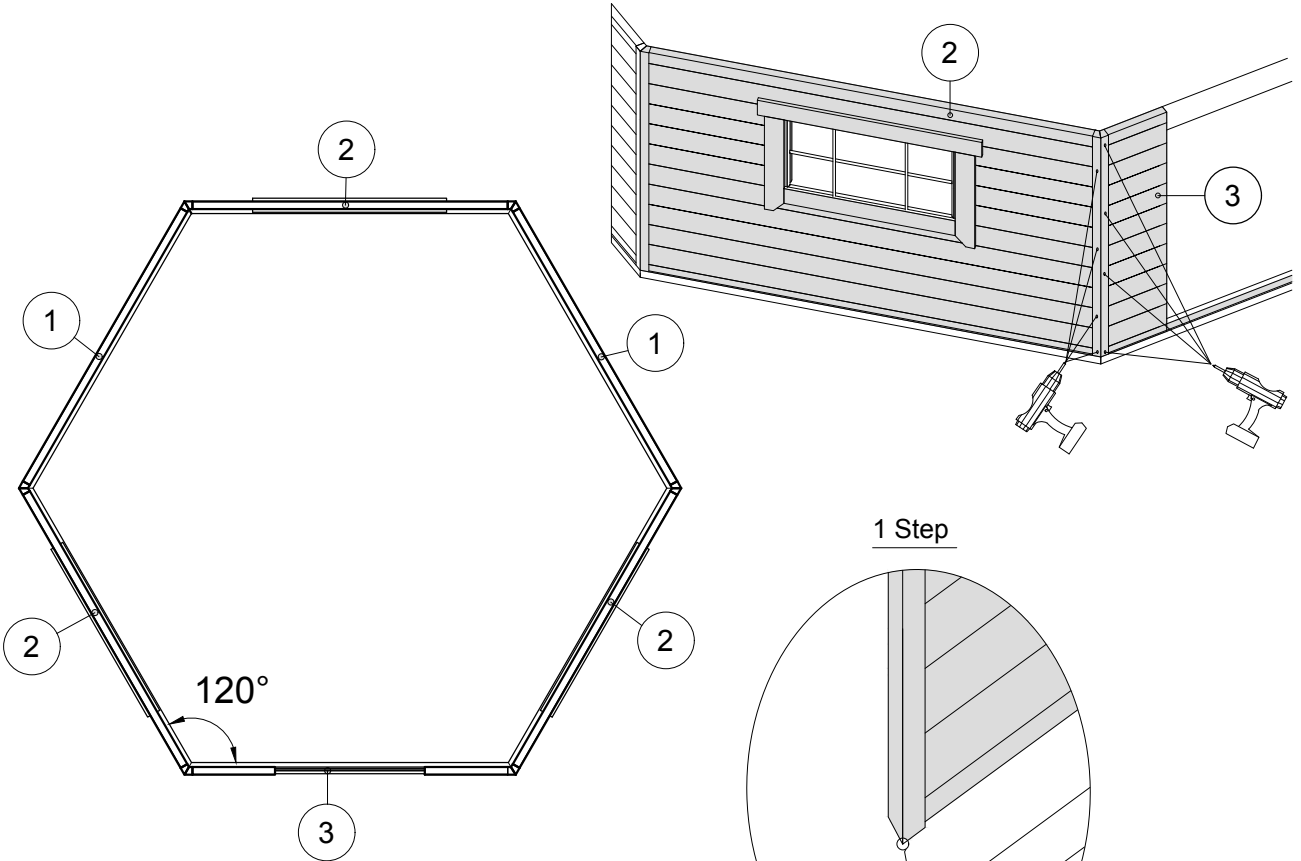

1 Step

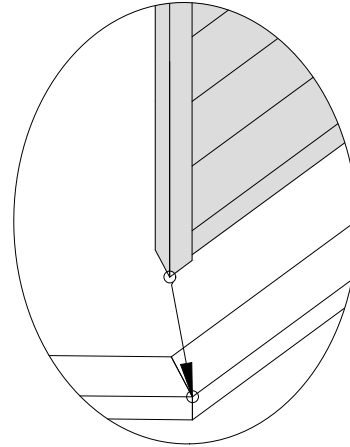

2 Step

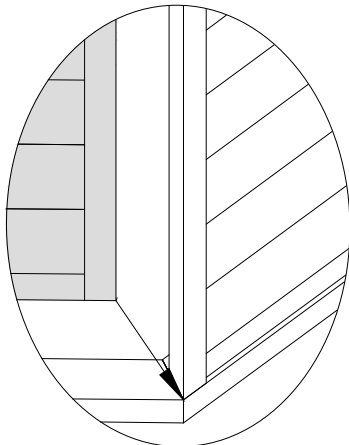

3 Step

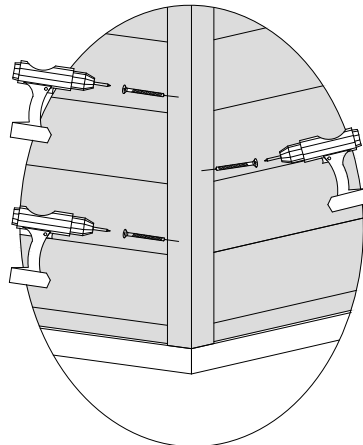

4 Step

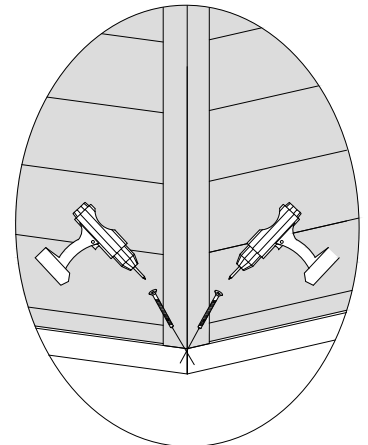

3. Grill cabin 9.2 with sloping walls DECORATION (SUPPORT) OUTSIDE

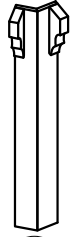
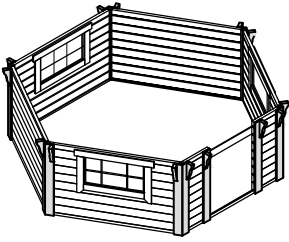

1 x6

GRp-6k-Apd-1173



2 x1

GRp9.2-Apd(k)-1163



3 x1

GRp9.2-Apd(d)-1163



4 x72

T-BC-4x50

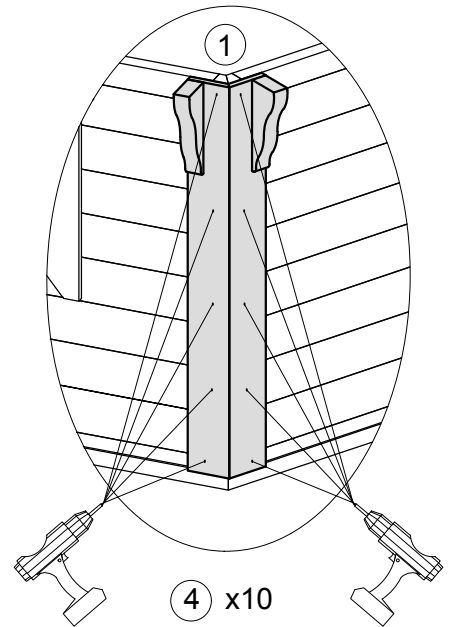
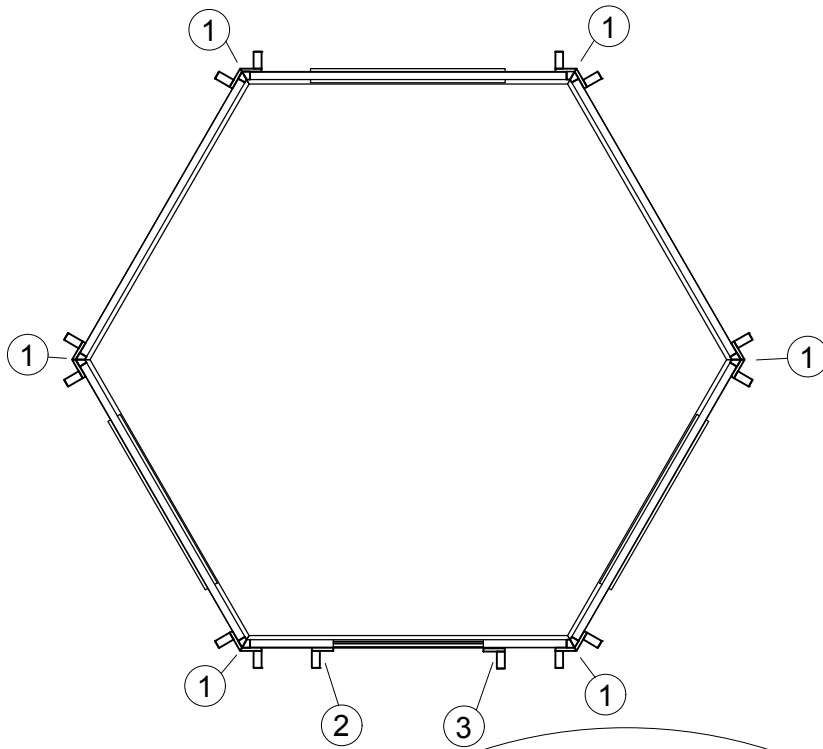

4 x10

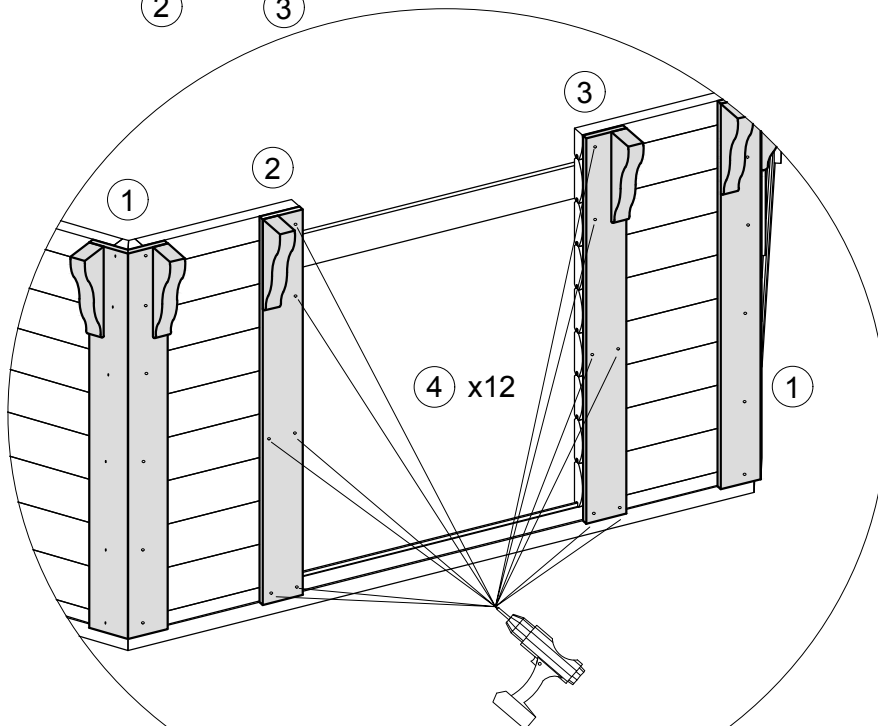

4 x12

4. Grill cabin 9.2 with sloping walls ROOF SUPPORT RING

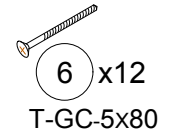
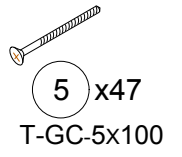
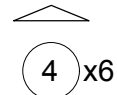
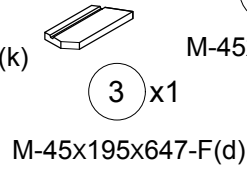
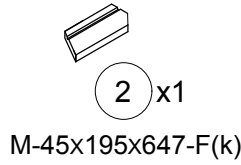
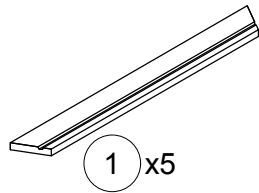
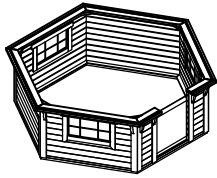

1 Step

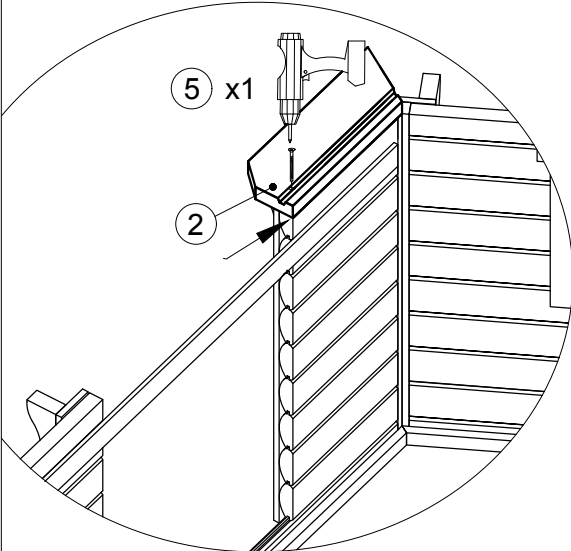

2 Step

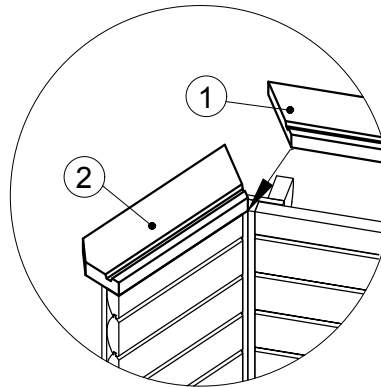

3 Step

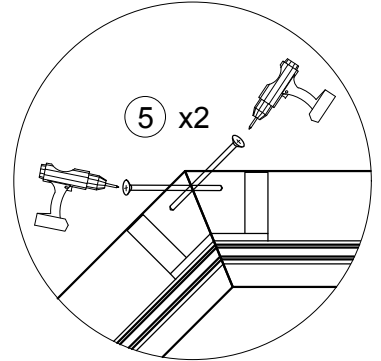

4 Step

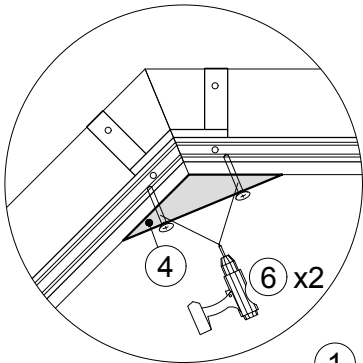

5 Step

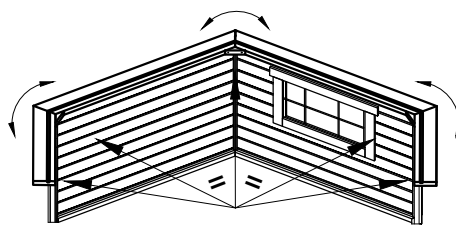

6 Step

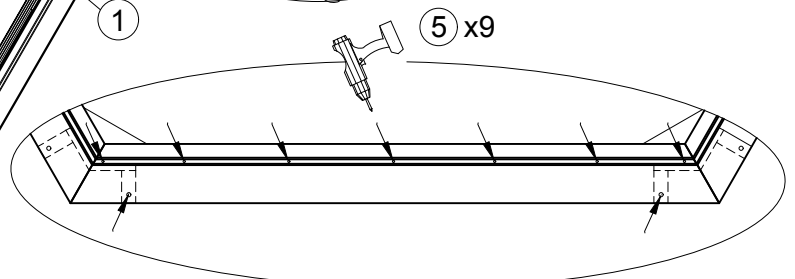
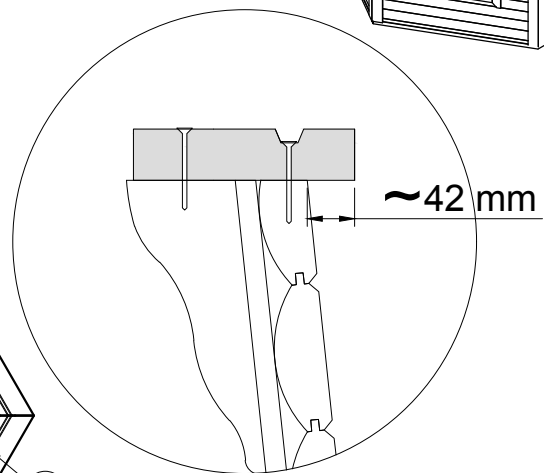
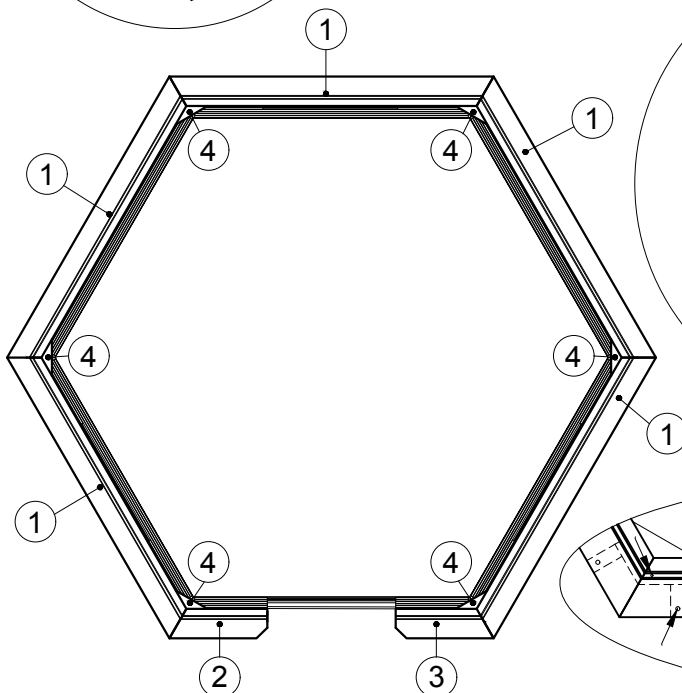
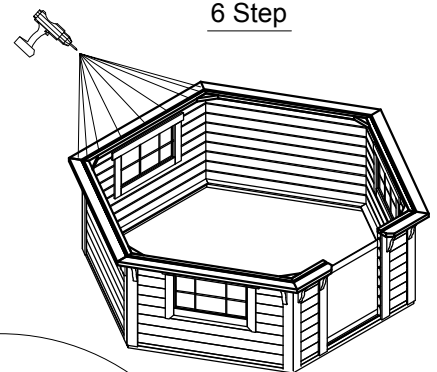

5. Grill cabin 9.2 with sloping walls FLOORS

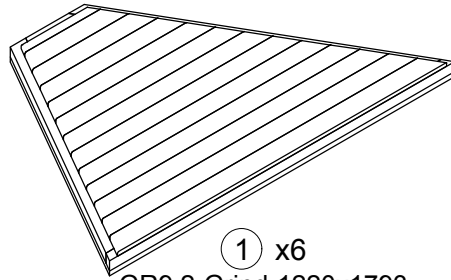
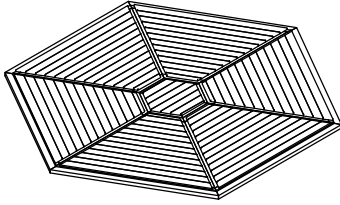

① x6
GR9.2-Grind-1220x1793
or
GR9.2-I-Grind-1220x1793
or
GR9.2-Spunt-1220x1793
or
GR9.2-I-Spunt-1220x1793

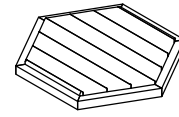

② x1
GR-6k-Grind-665x768
or
GR-6k-I-Grind-665x768
or
GR-6k-Spunt-665x768
or
GR-6k-I-Spunt-665x768



③ x42
T-BC-3.5x45

1 Step

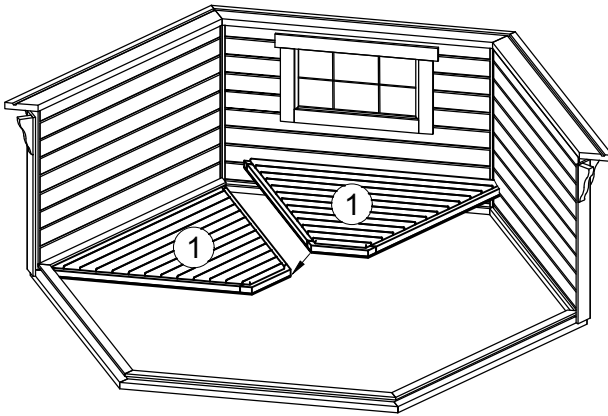

2 Step

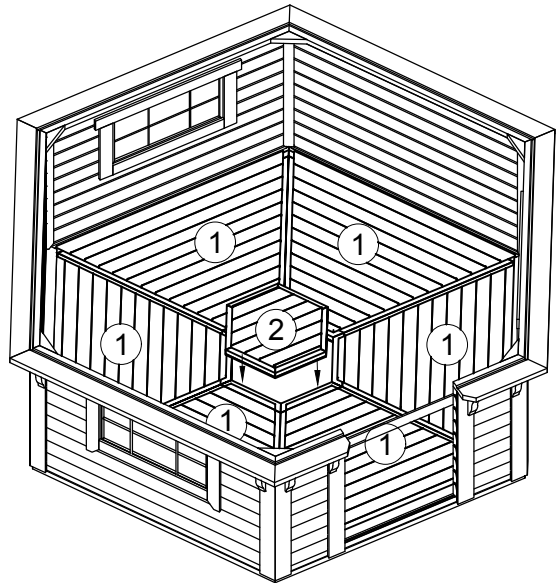

3 Step

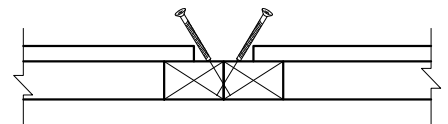
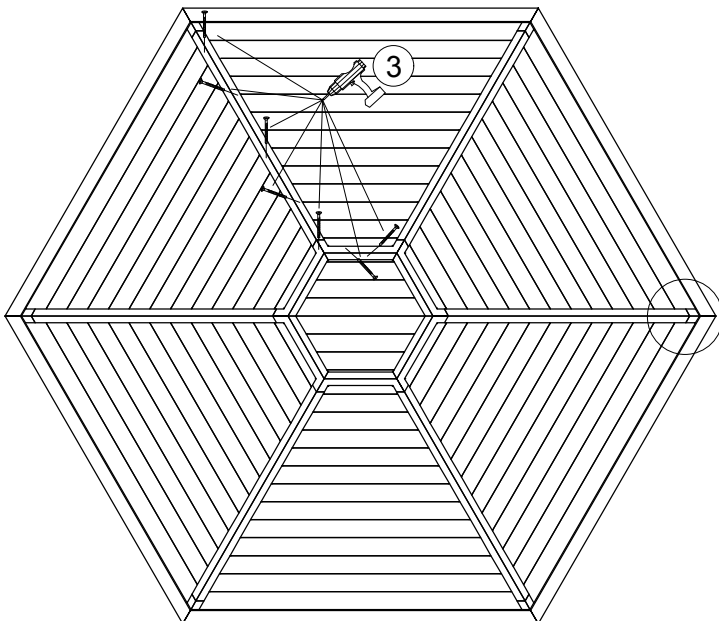

6. Grill cabin 9.2 with sloping walls FLOORS FINISHING BOARDS

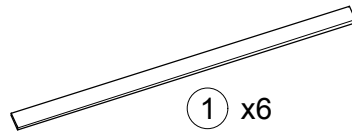
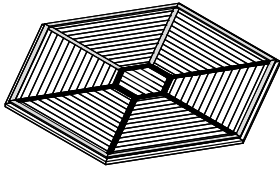

① x6
M-18x70x1367
or
Spunt-28x70x1367



② x6
M-18x70x404-F
or
Spunt-28x70x404-F

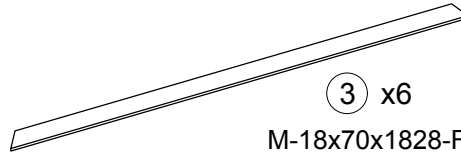

③ x6
M-18x70x1828-F

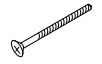

④ x90
T-GC-3.5x45

1 Step

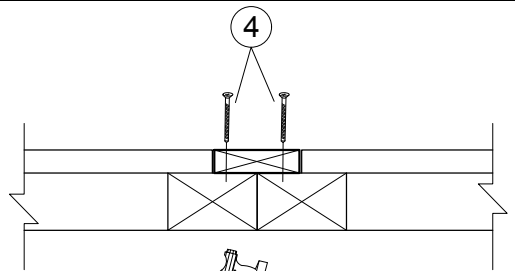
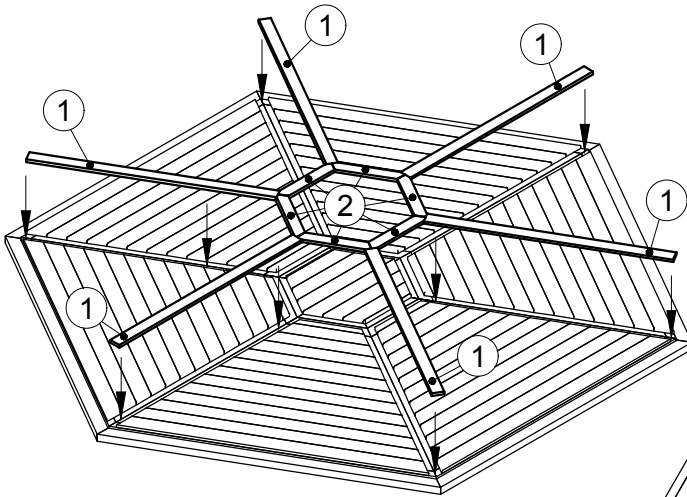

2 Step

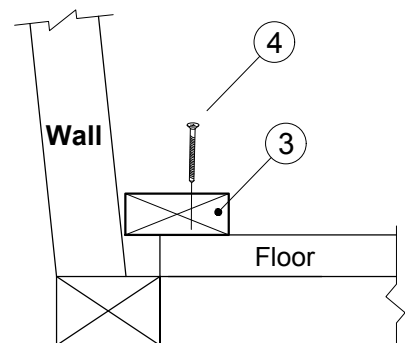
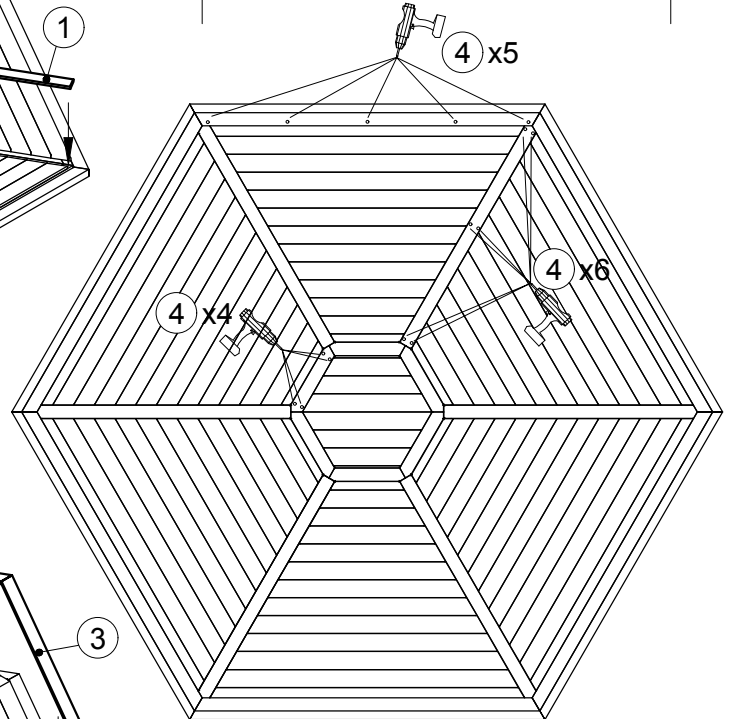
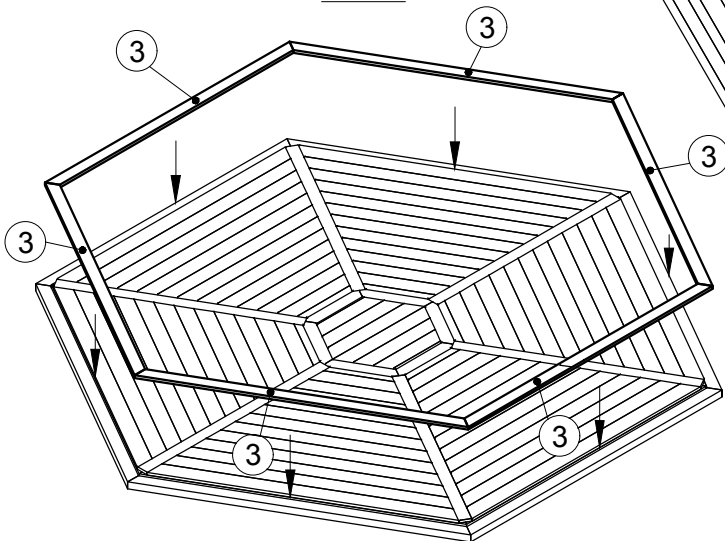

7.1 Grill cabin 9.2 with sloping walls

ROOF

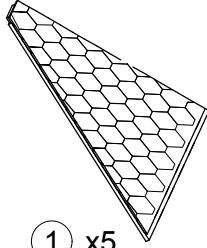

① x5
GR9.2-Stog-2022x2147
or
GR9.2-I-Stog-2022x2147

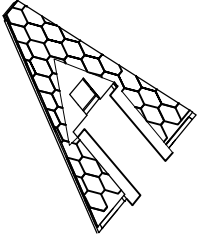

② x1
GR9.2-StogD-2022x2147
or
GR9.2-I-StogD-2022x2147

OR

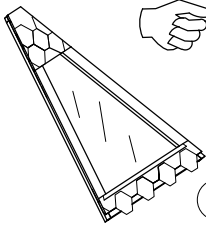
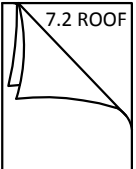



③
GR9.2-StogL-2022x2147
or
GR9.2-I-StogL-2022x2147

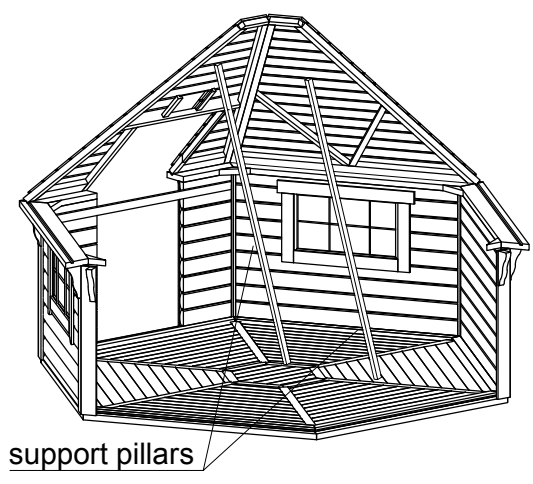

④ x78
T-GC-5x80

1 Step



2 Step

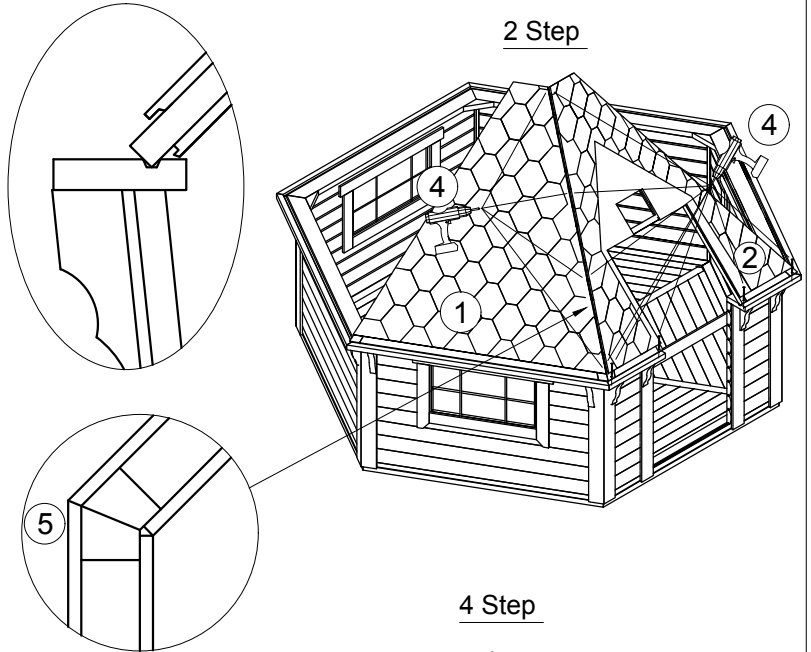

3 Step

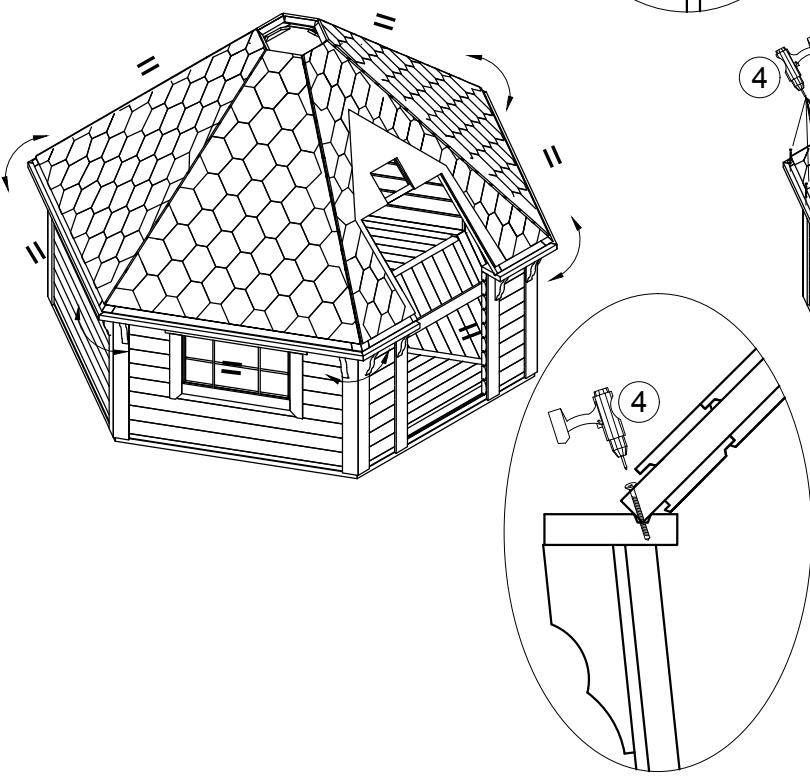

4 Step

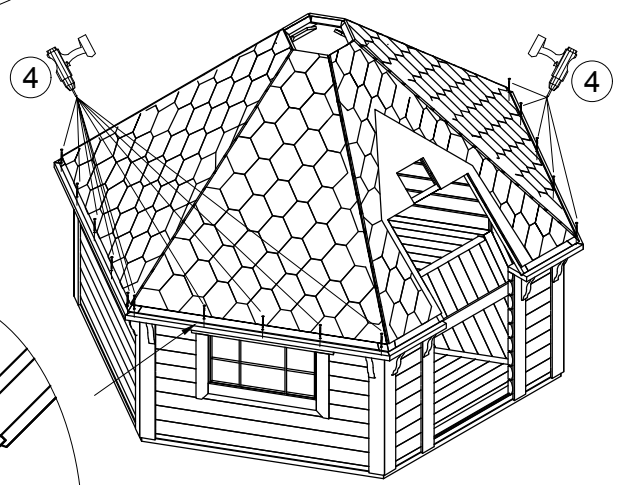

7.2 Grill cabin 9.2 with sloping walls
ROOF

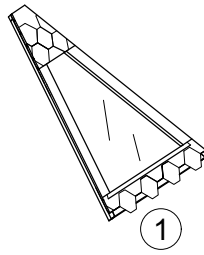
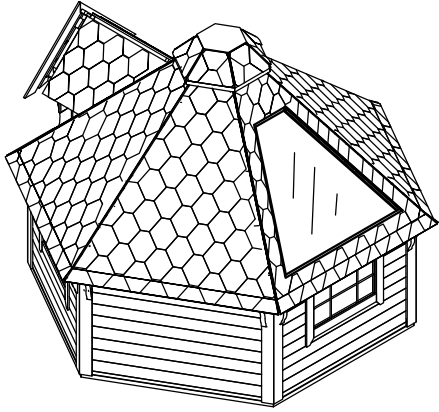

GR9.2-StogL-2022X2147
or
GR9.2-I-StogL-2022X2147

1 Step

A-A

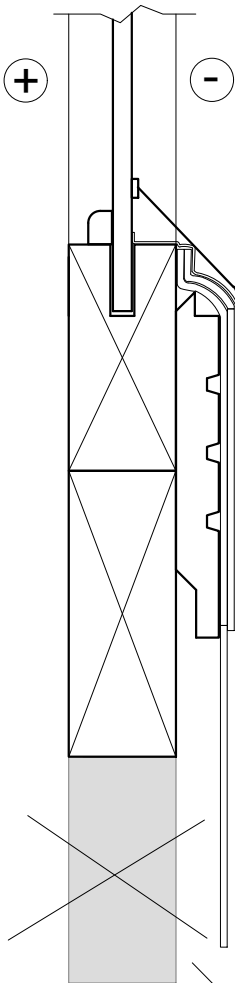

2 Step

A-A

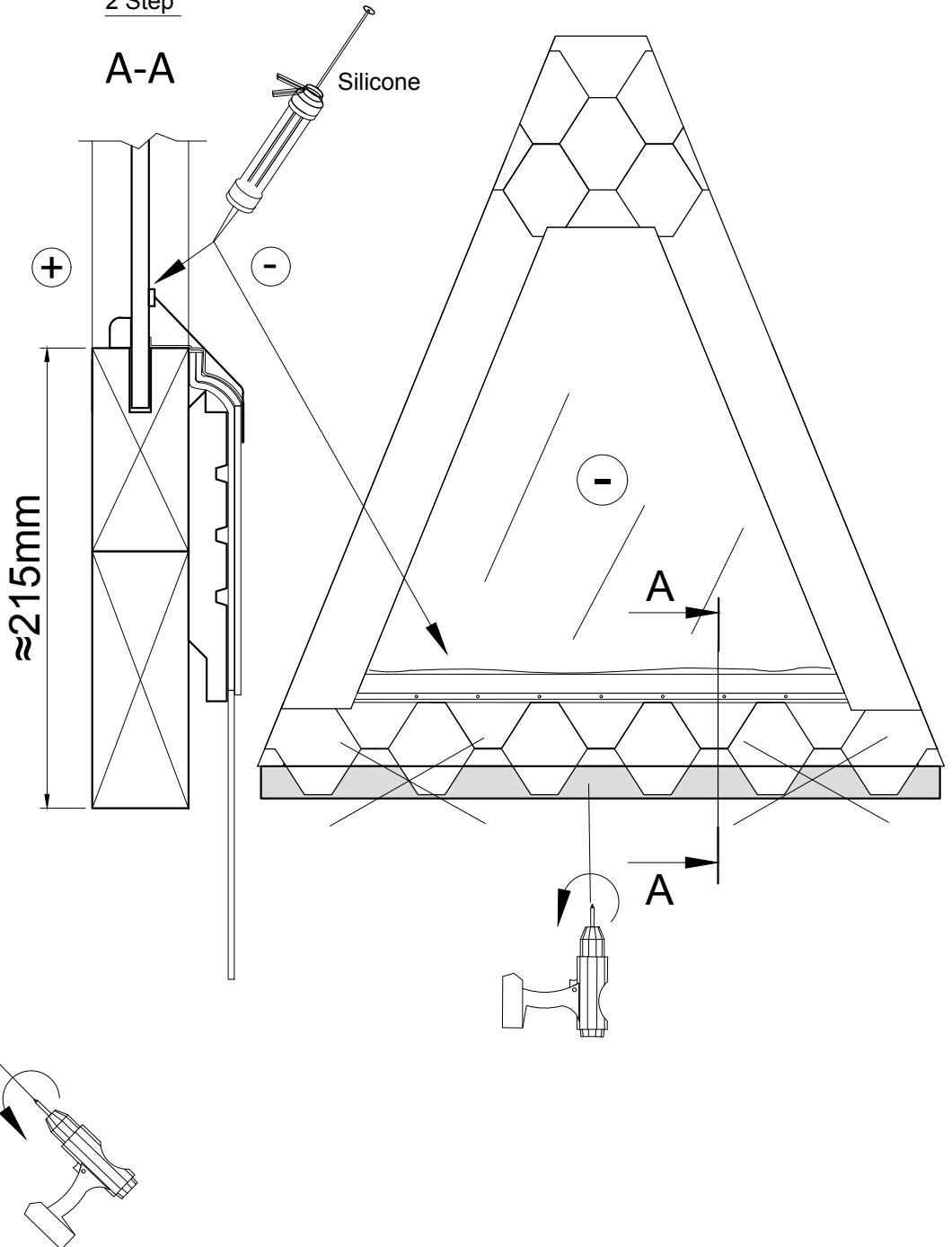

8. Grill cabin 9.2 with sloping walls ENTRANCE SUPPORT



① x1

M-45x195x1630-A850-CNC(k)

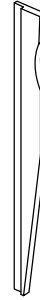

② x1

M-45x195x1630-A850-CNC(d)



③ x6

T-BC-4x50



④ x2

T-GC-5x80



⑤ x2

T-GC-5x100

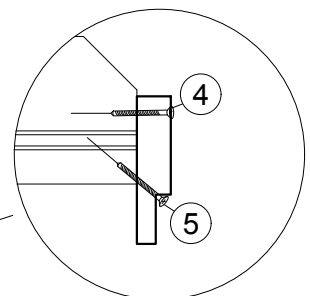
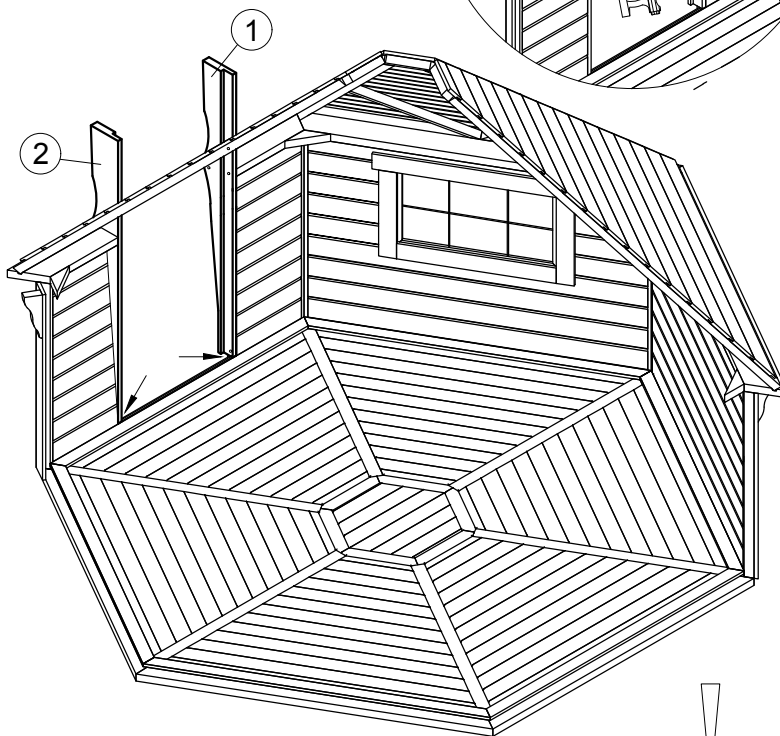
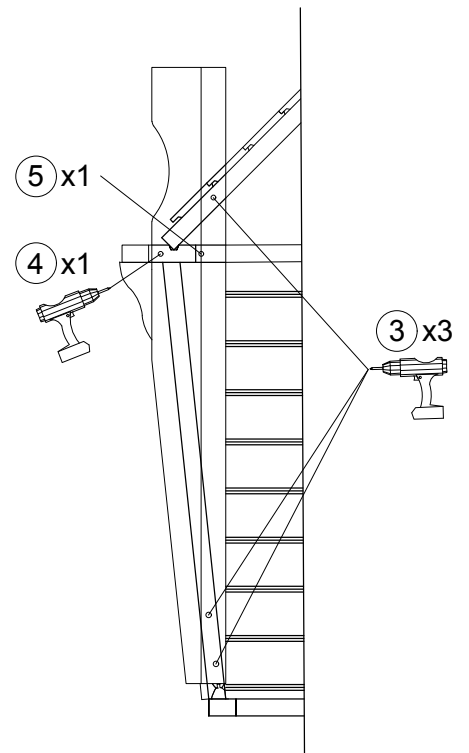
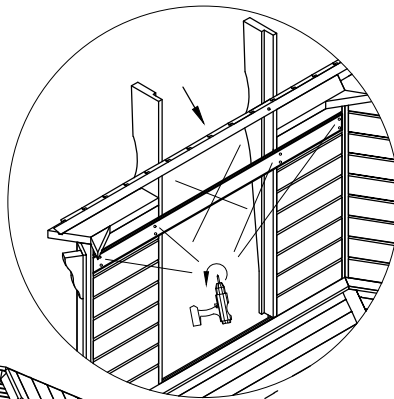

850

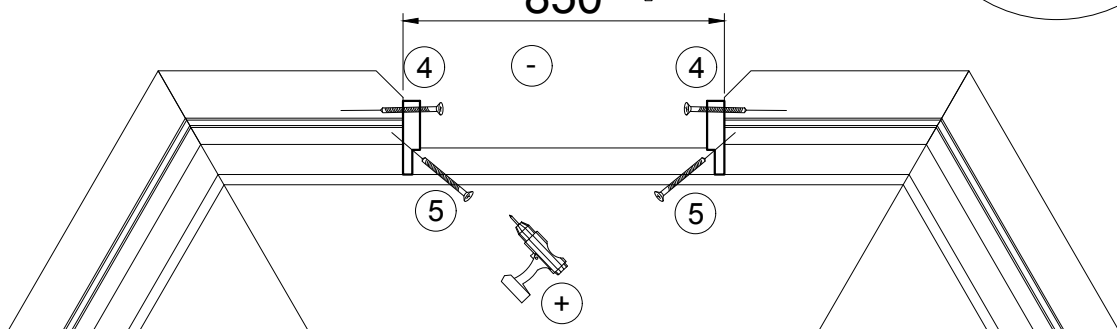

9. Grill cabin 9.2 with sloping walls OUTSIDE DOOR



① x1
PUS00013

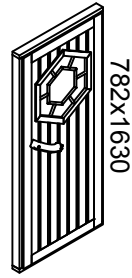

② x6
T-GC-5x60

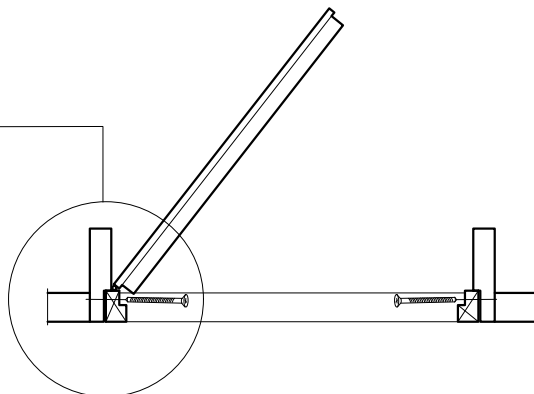
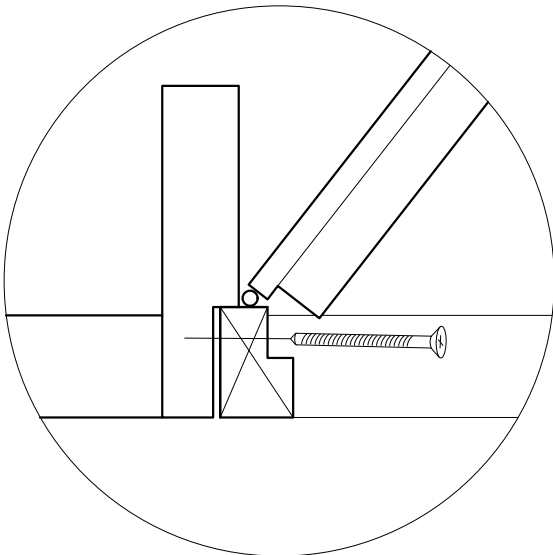
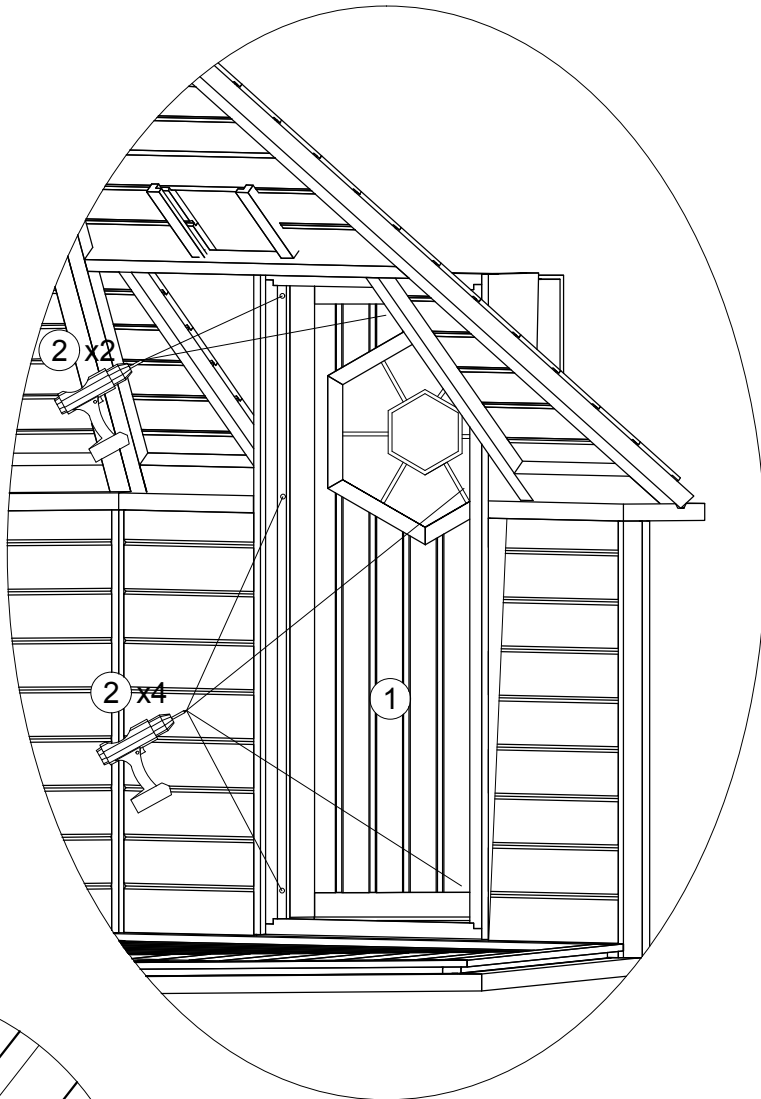

9.1 Grill cabin 9.2 with sloping walls
INSIDE FINISHING BOARD

① x2
M-18x70x1624



② x16
T-GC-3.5x45

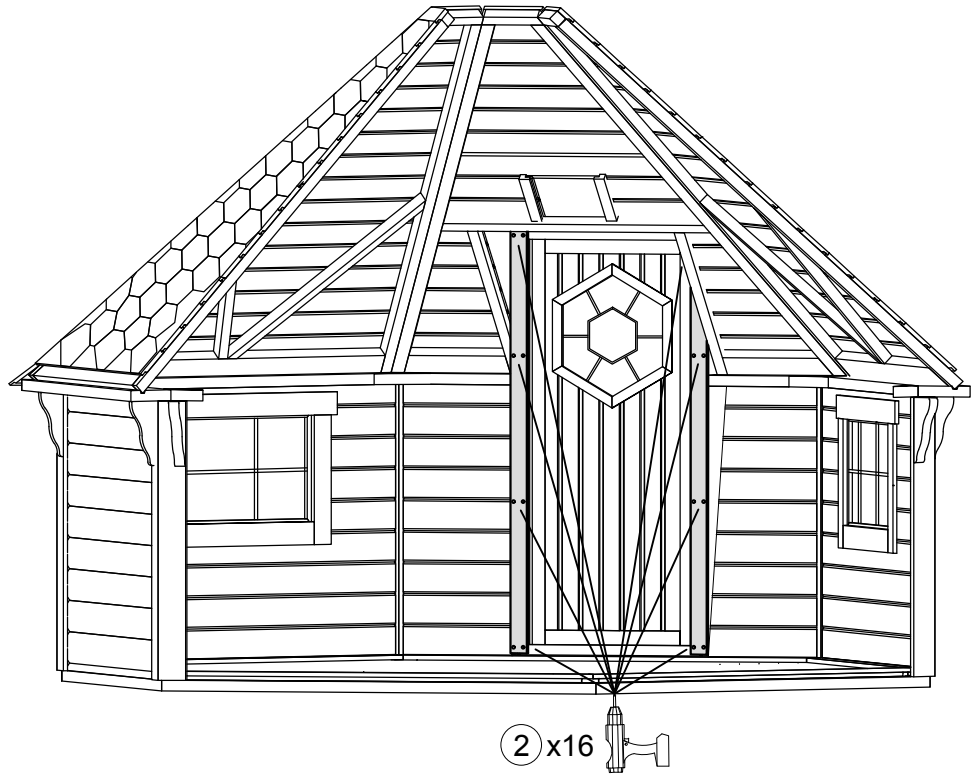
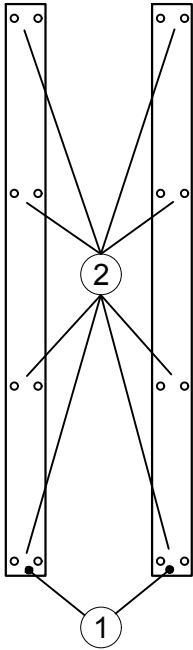

10. Grill cabin 9.2 with sloping walls ENTRANCE ASSEMBLY



- ① x1
GR-trikamp-313x331-(k)
- ② x1
GR-trikamp-313x331-(d)
- ③ x4
T-GC-5x100

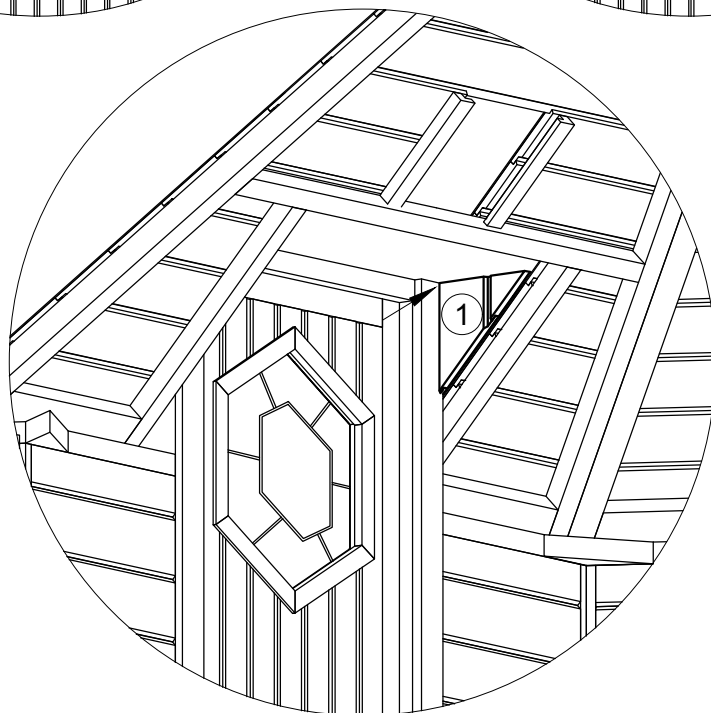
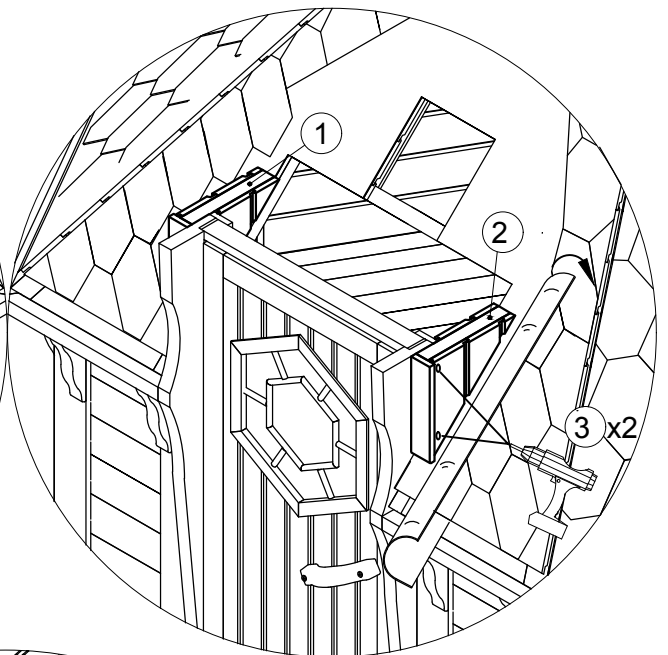
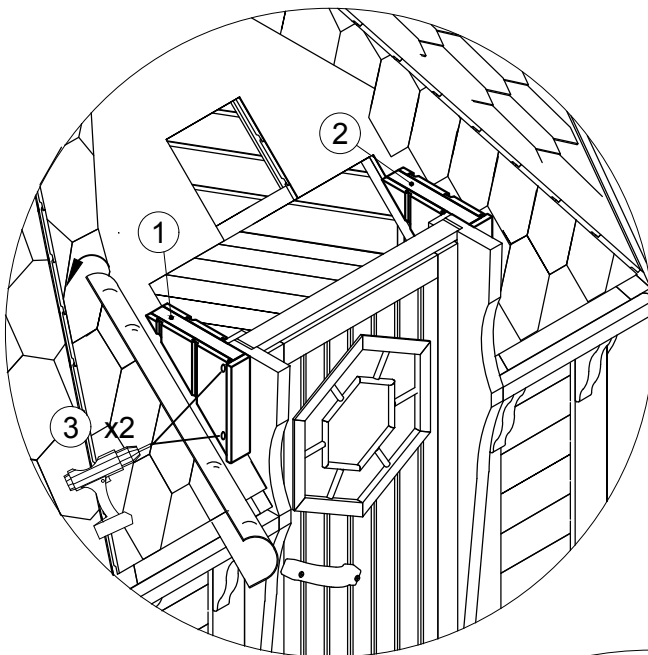

10.1 Grill cabin 9.2 with sloping walls
ENTRANCE ASSEMBLY

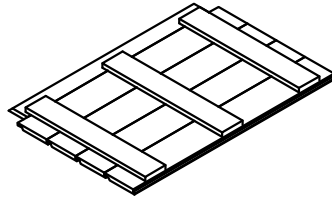

① x1
GR-lubos-636x939



② x6
T-GC-4x70

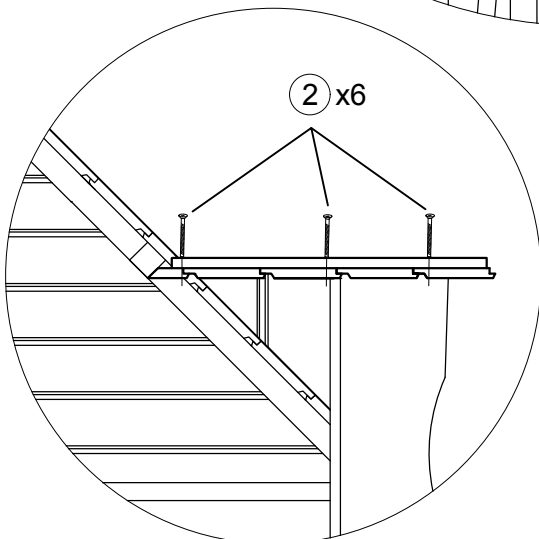
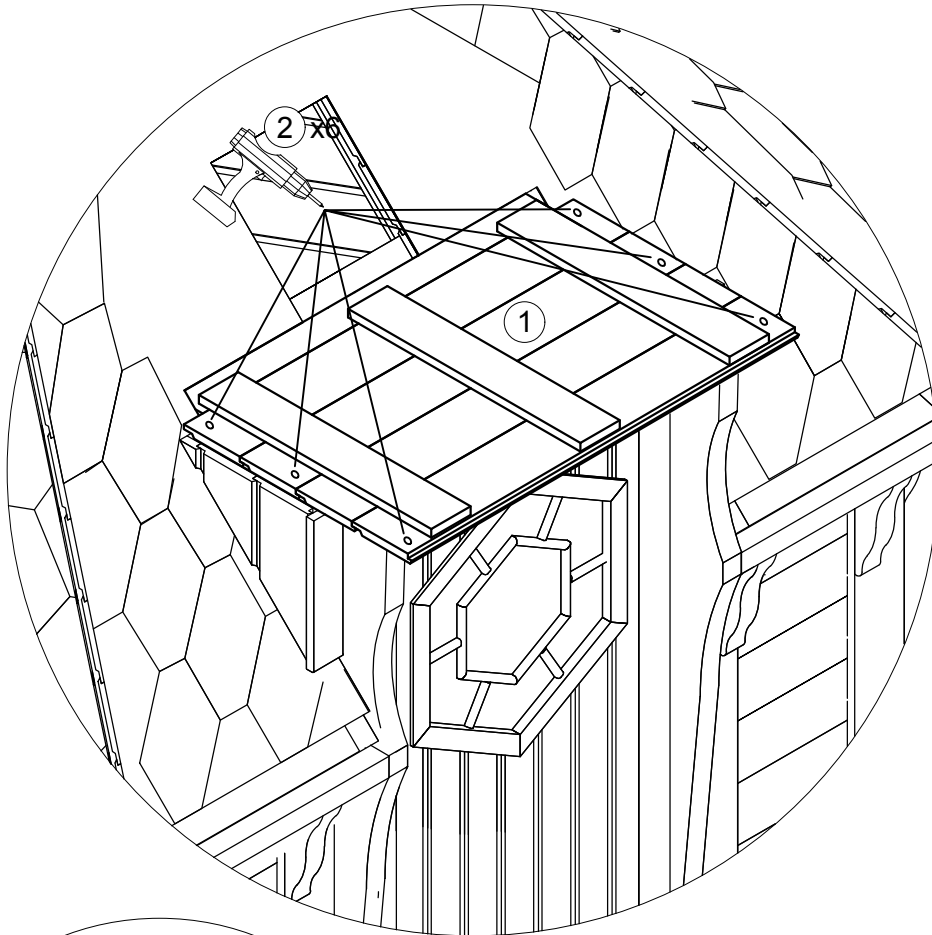

10.2 Grill cabin 9.2 with sloping walls ENTRANCE ASSEMBLY

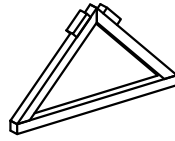
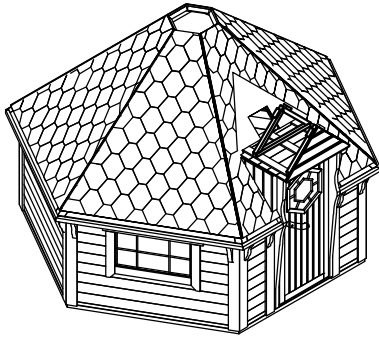

① x1

GR-Stog-trik-453x815

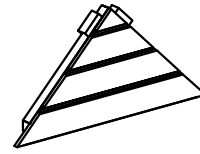

② x1

GR-Pr-trik-491x981



③ x4

T-GC-5x100



④ x2

T-GC-4x70

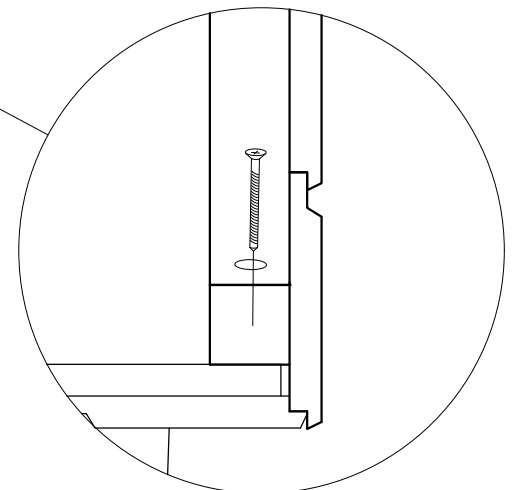
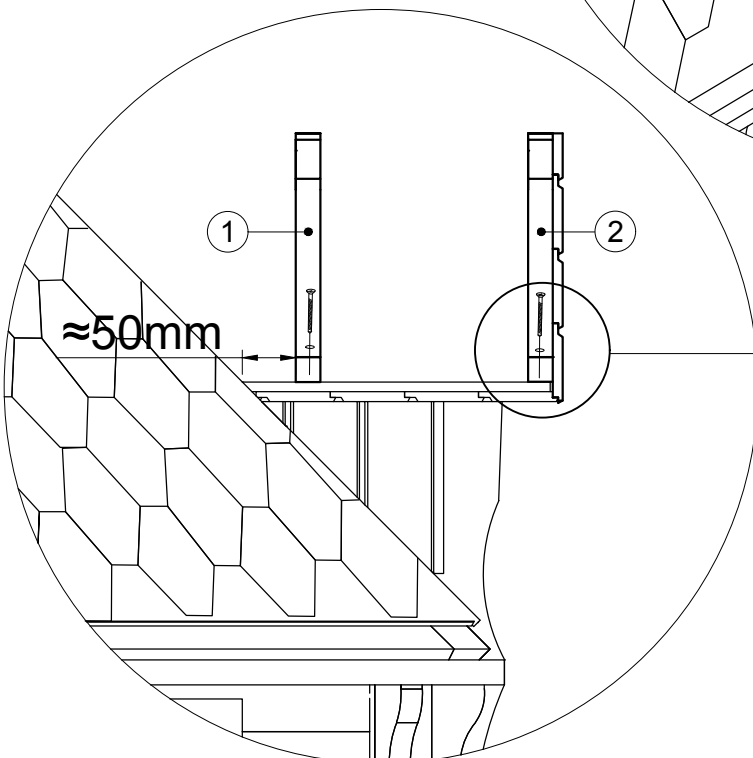
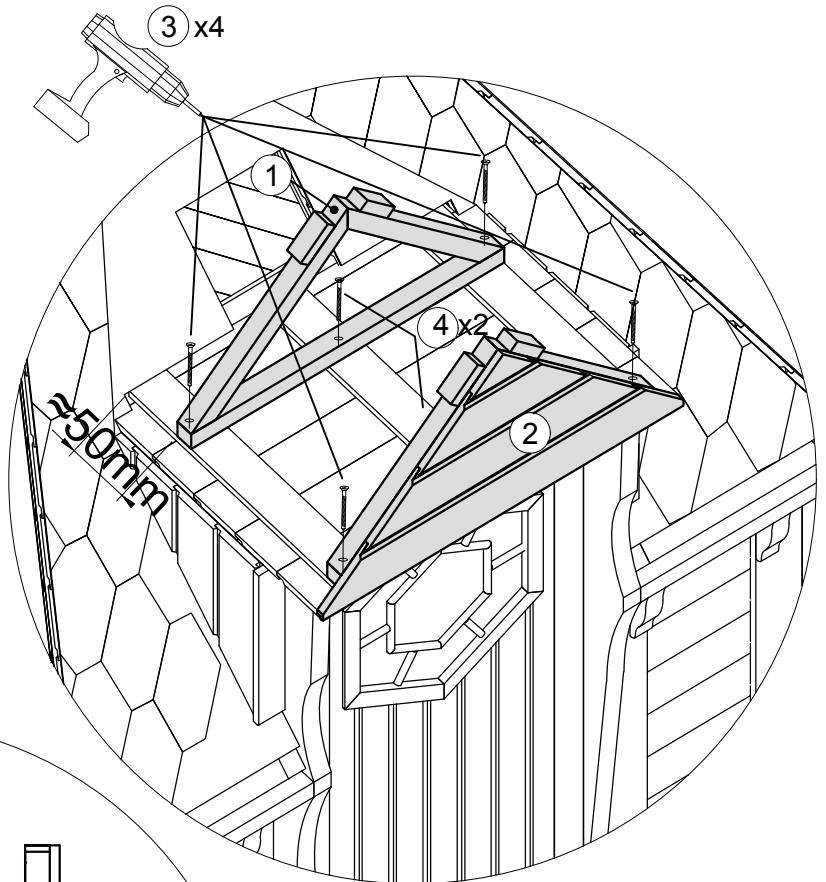

10.3 Grill cabin 9.2 with sloping walls ENTRANCE ASSEMBLY

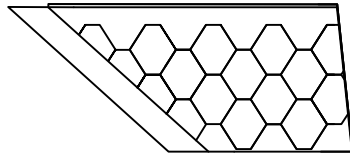

① x1

GR-Stog-845x1090-(k)

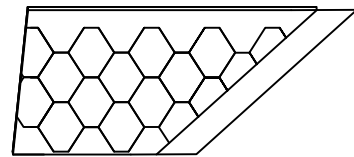

② x1

GR-Stog-845x1090-(d)



③ x8
T-GC-5x80

1 Step

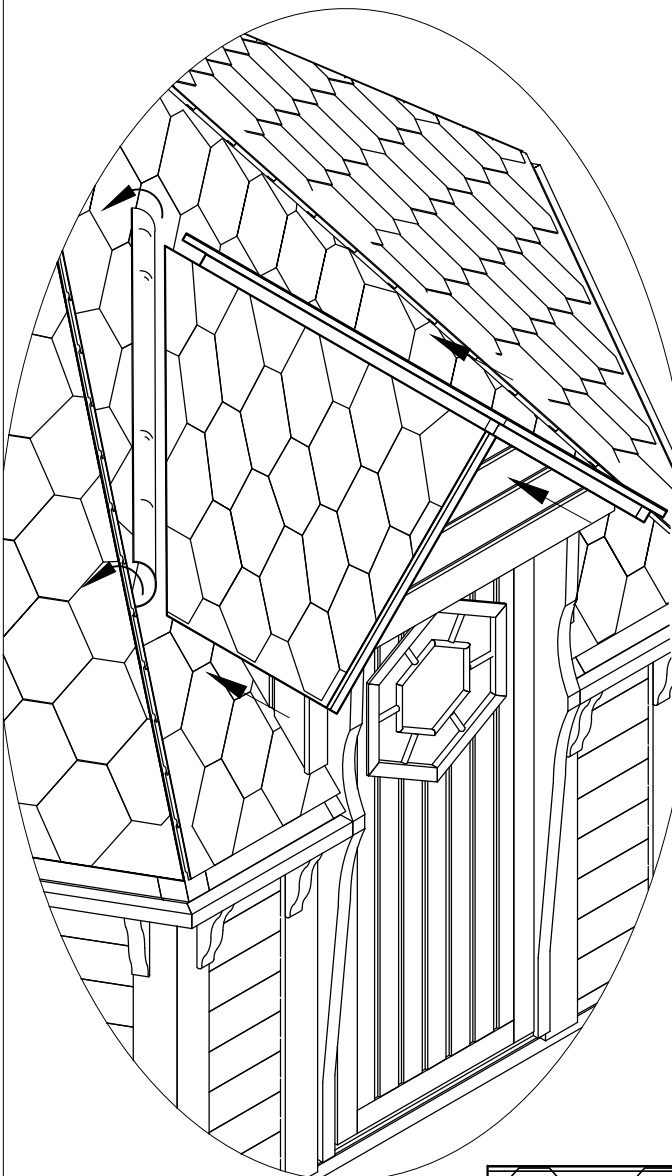

2 Step

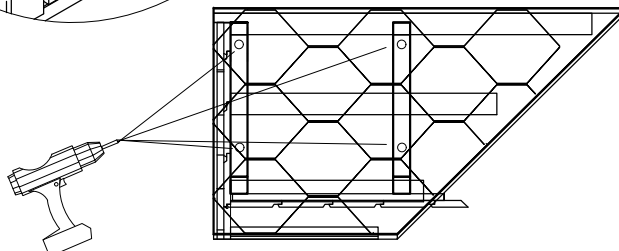
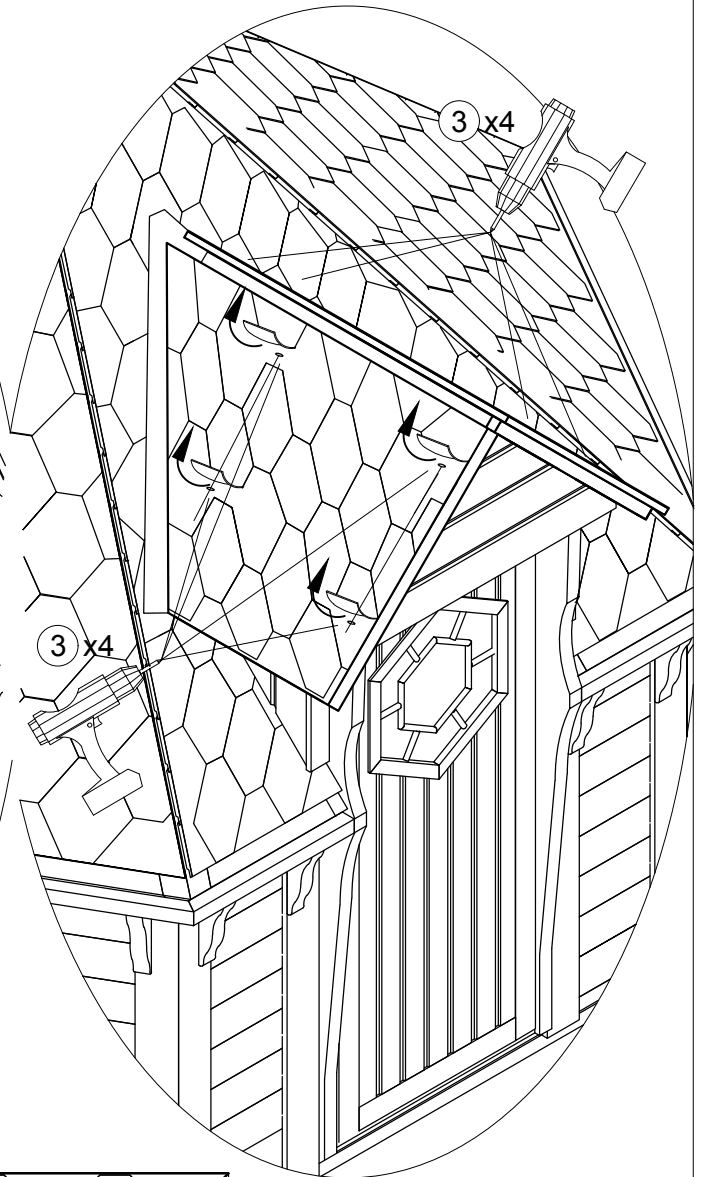

10.4 Grill cabin 9.2 with sloping walls ENTRANCE ASSEMBLY

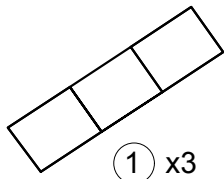
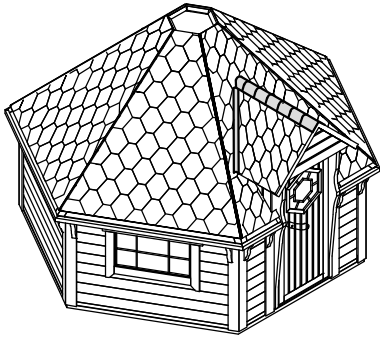

Bitumines-
cerpes-3x250x1000

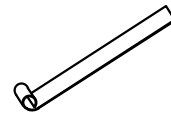

Bitumine-
juosta-3x70x1360

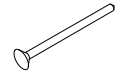

T-V-2x20
x 64

1 Step

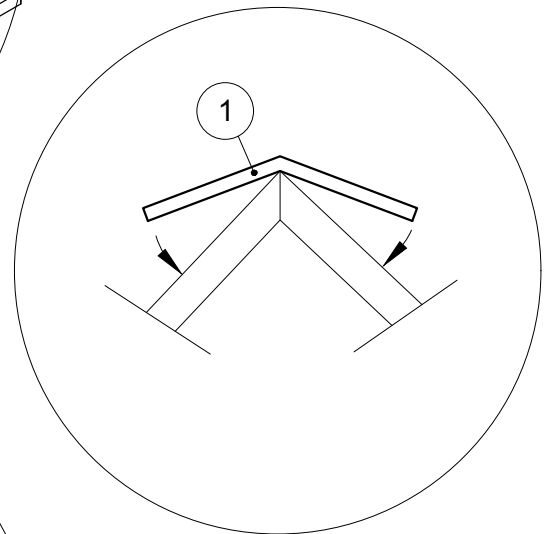
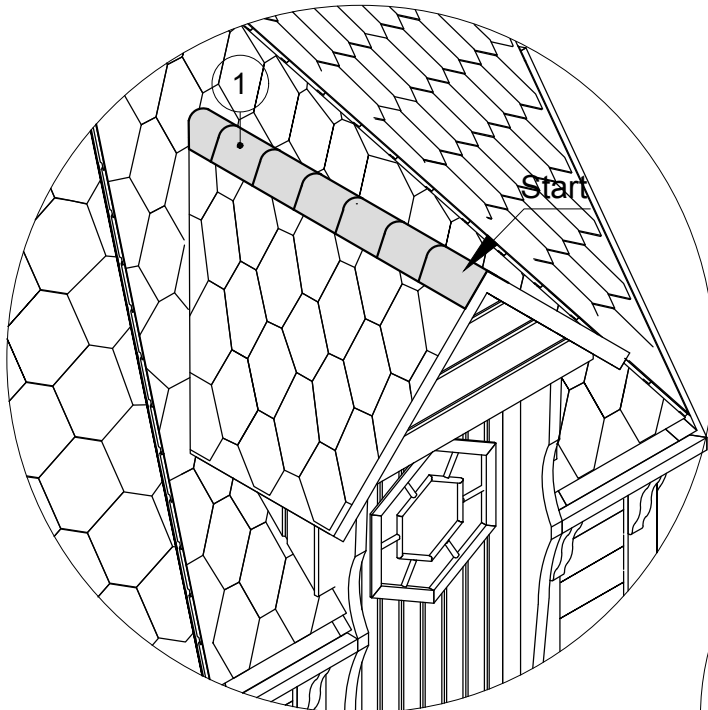

2 Step

③ x28

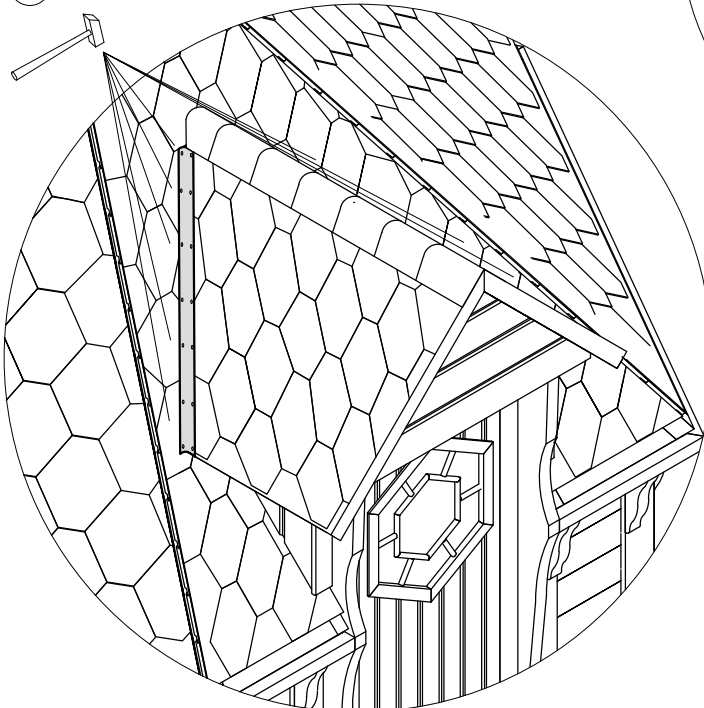

11. Grill cabin 9.2 with sloping walls ROOF FINISHING

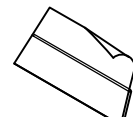
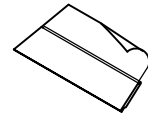
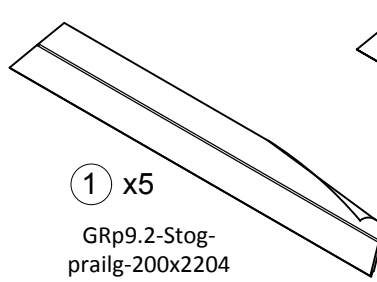

1 Step

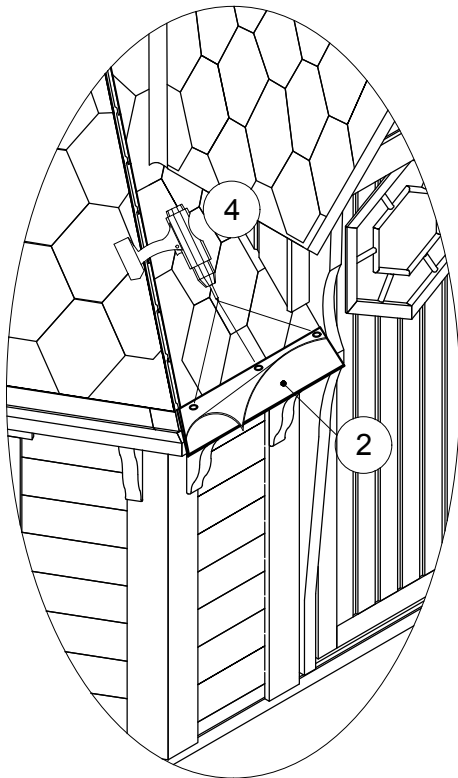

2 Step

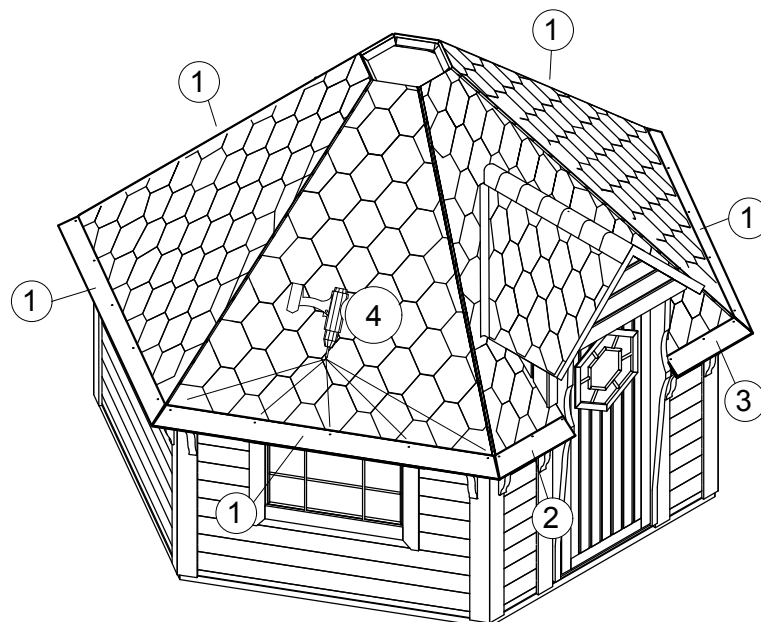
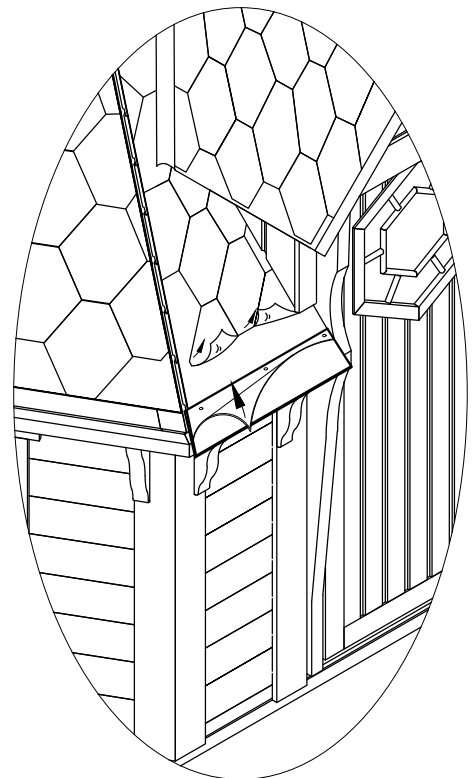
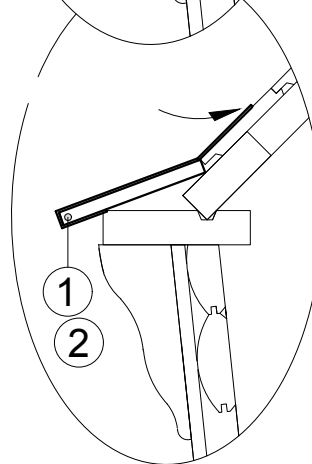
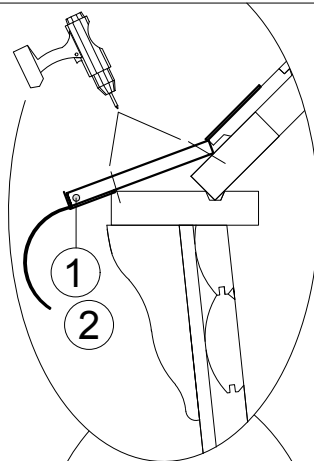

11.1 Grill cabin 9.2 with sloping walls ROOF FINISHING

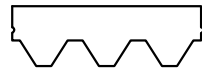
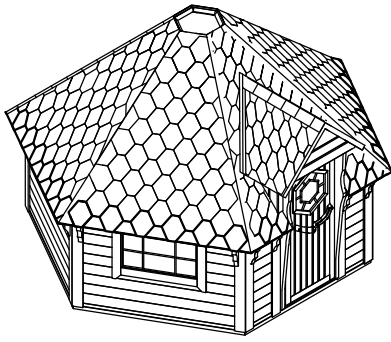

① x13

Bituminous-cerpes
-3x317x1000

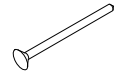

② x 150

T-V-2x20

1 Step

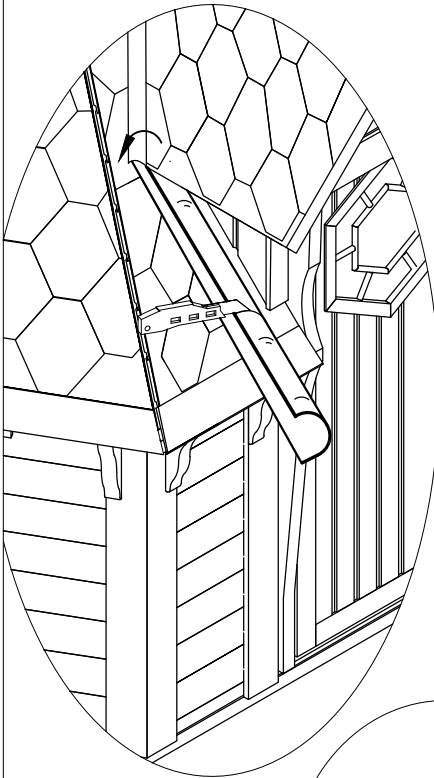

2 Step

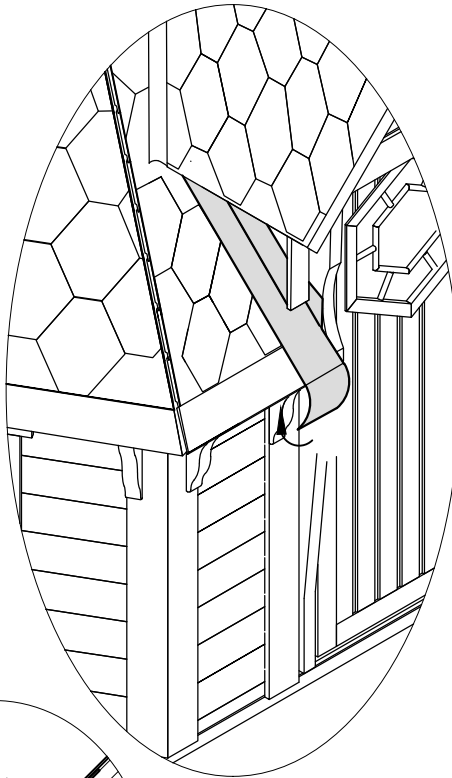

3 Step

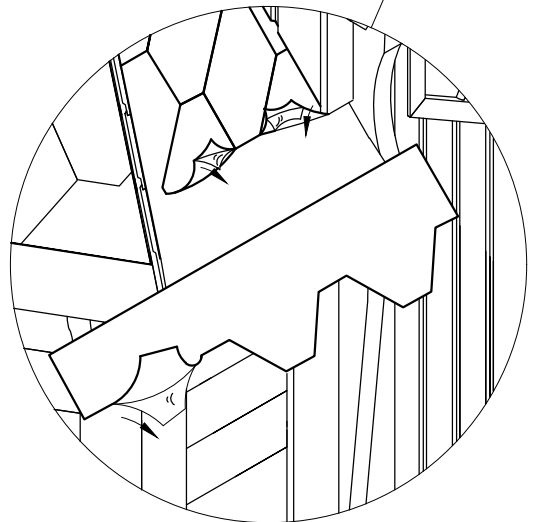
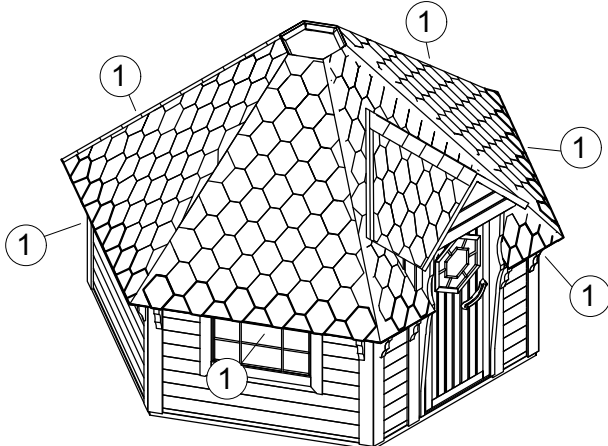
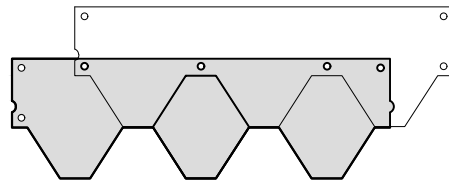
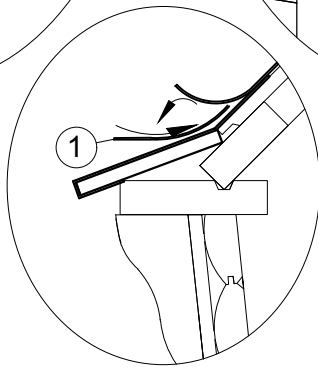
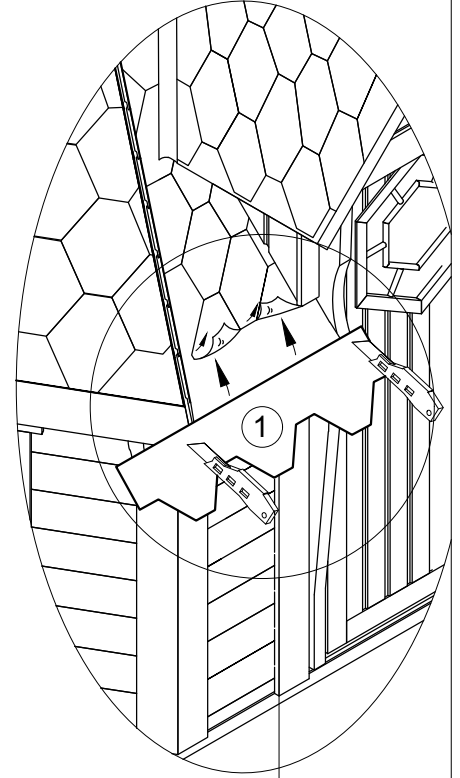

11.2 Grill cabin 9.2 with sloping walls ROOF FINISHING

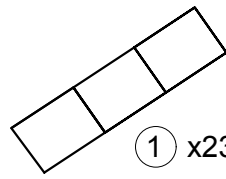

Bitumines-
cerpes-3x250x1000

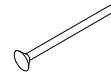

② x 340

T-V-2x20

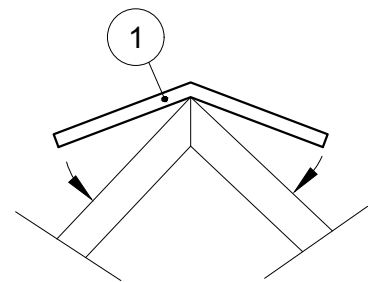
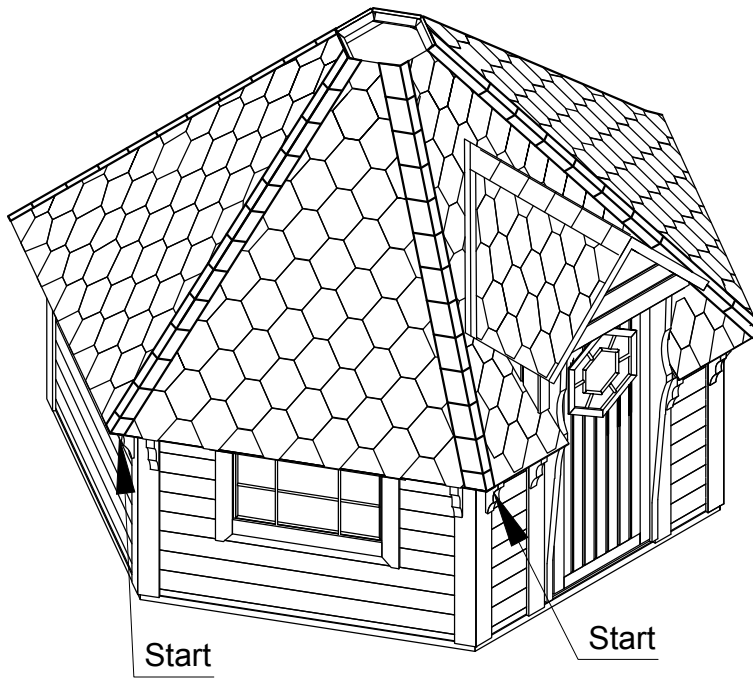

Start

Start

Start

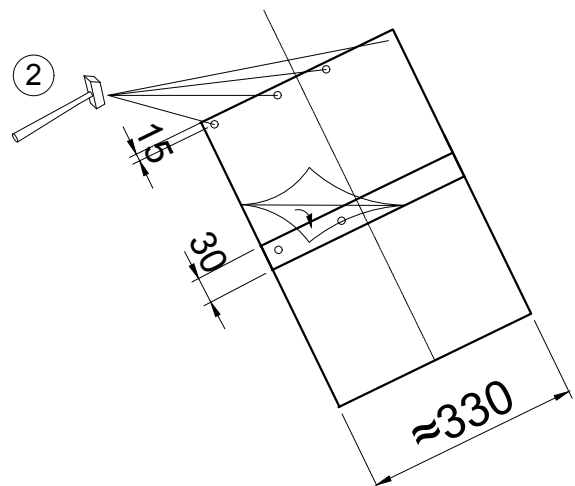
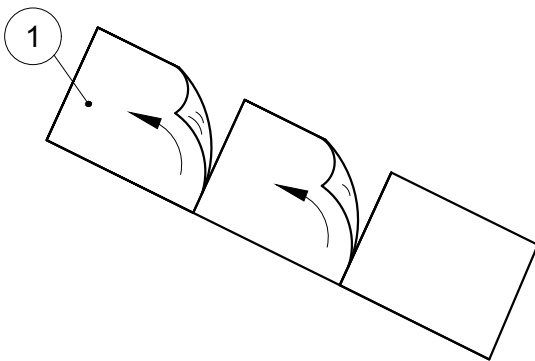

12. Grill cabin 9.2 with sloping walls OUTSIDE FINISHING BOARD



M-18x95x820-CNC

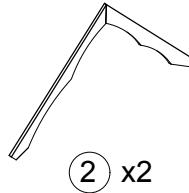

M-18x110x915-CNC



T-GC-3.5x45

1 Step

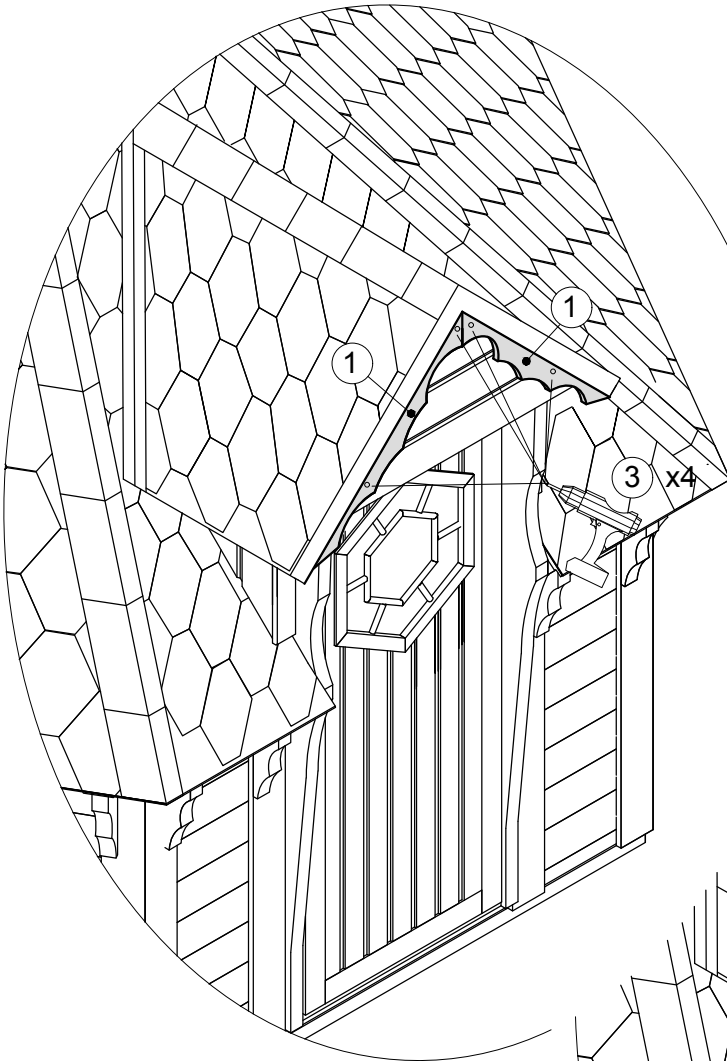

2 Step

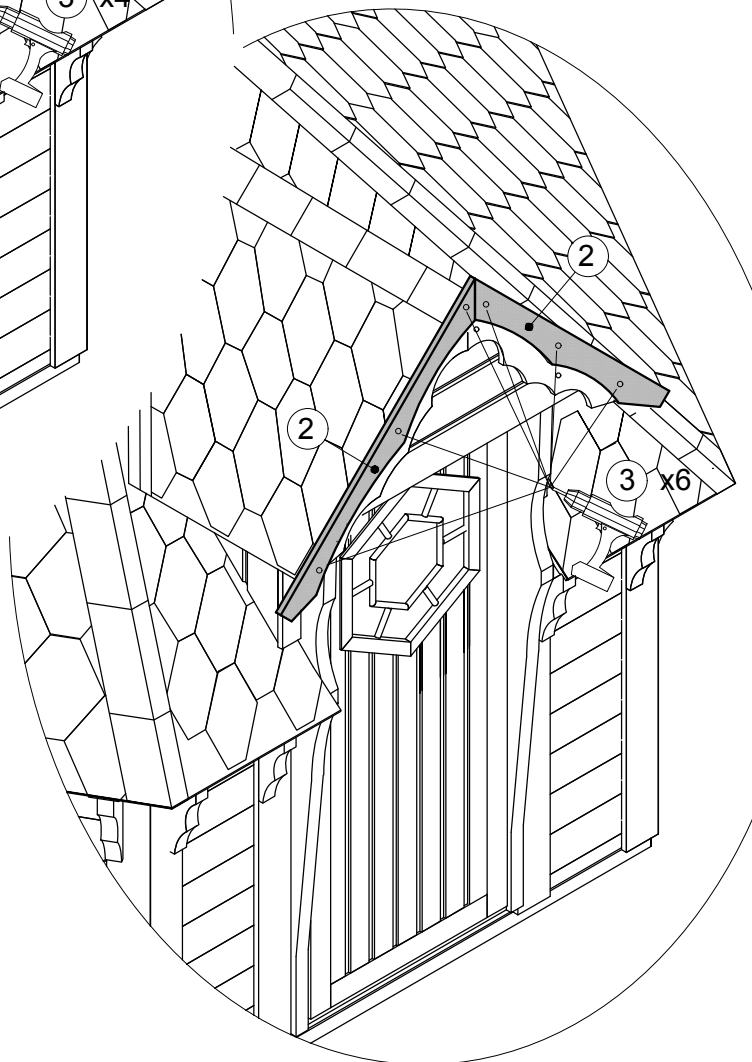

13. Grill cabin 9.2 with sloping walls INSIDE FINISHING BOARD

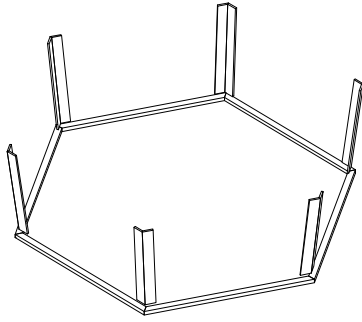

① x12
M-18x120x1110-F



② x36
T-GC-3.5x45

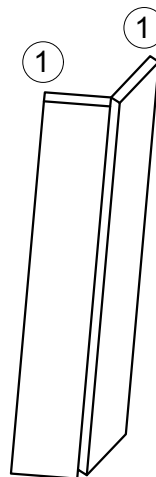
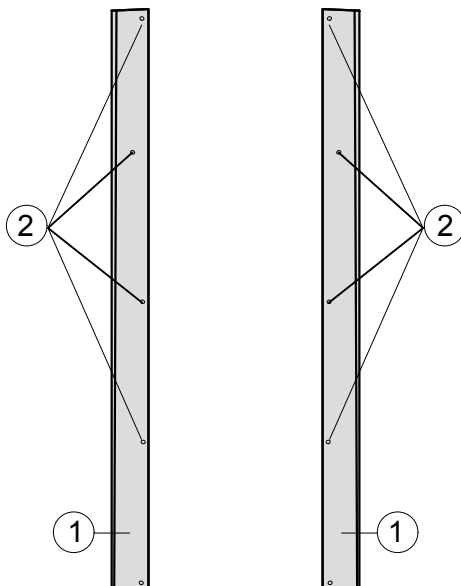
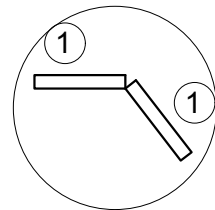
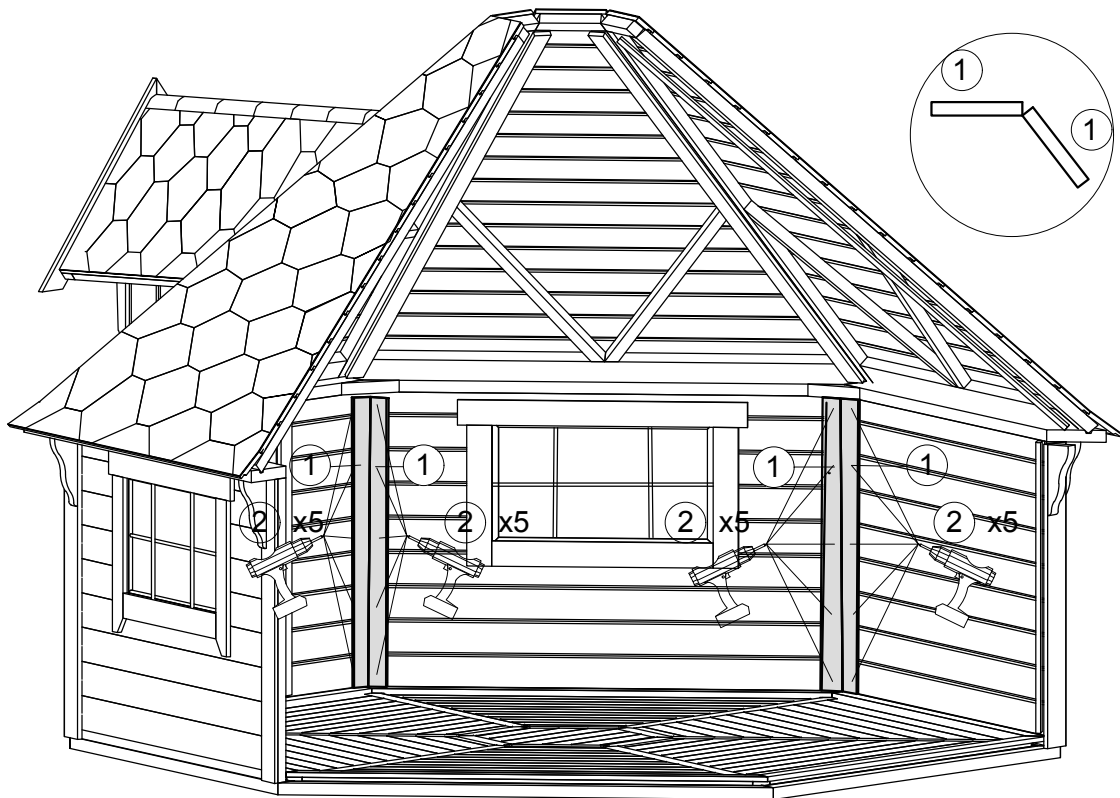

13.1 Grill cabin 9.2 with sloping walls
INSIDE FINISHING BOARD

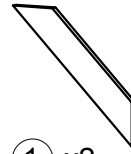

① x2
M-18x83x488-F



② x12
T-GC-3.5x45

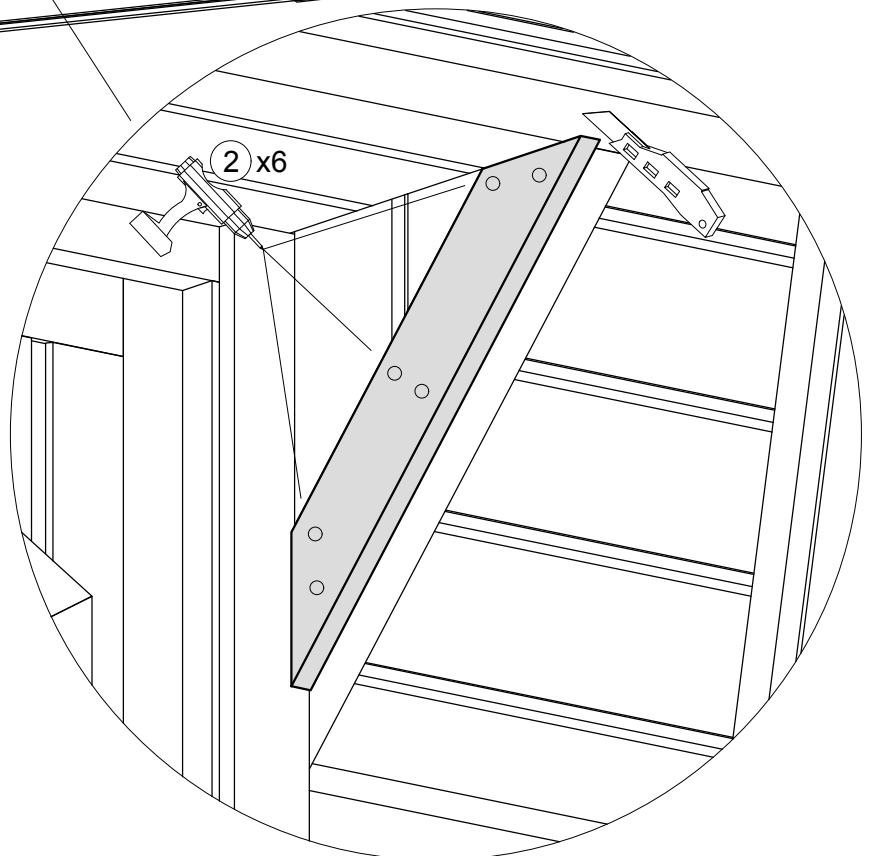
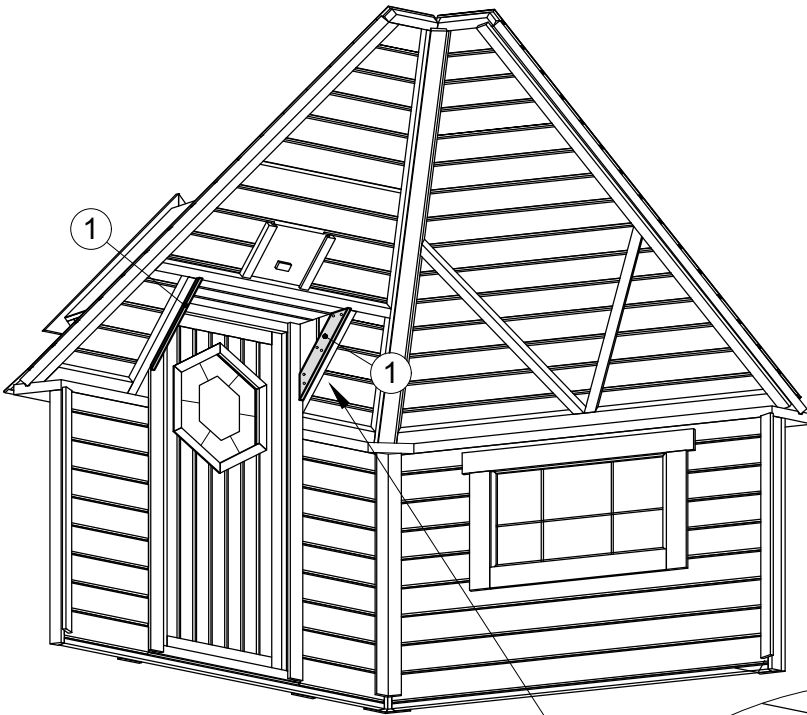

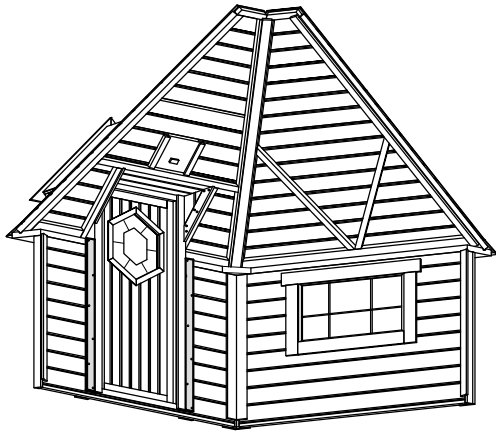

13.2 Grill cabin 9.2 with sloping walls INSIDE FINISHING BOARD



① x2
M-18x70x1150
or
M-18x70x1280
or
M-18x70x1410



② x12
T-GC-3.5x45

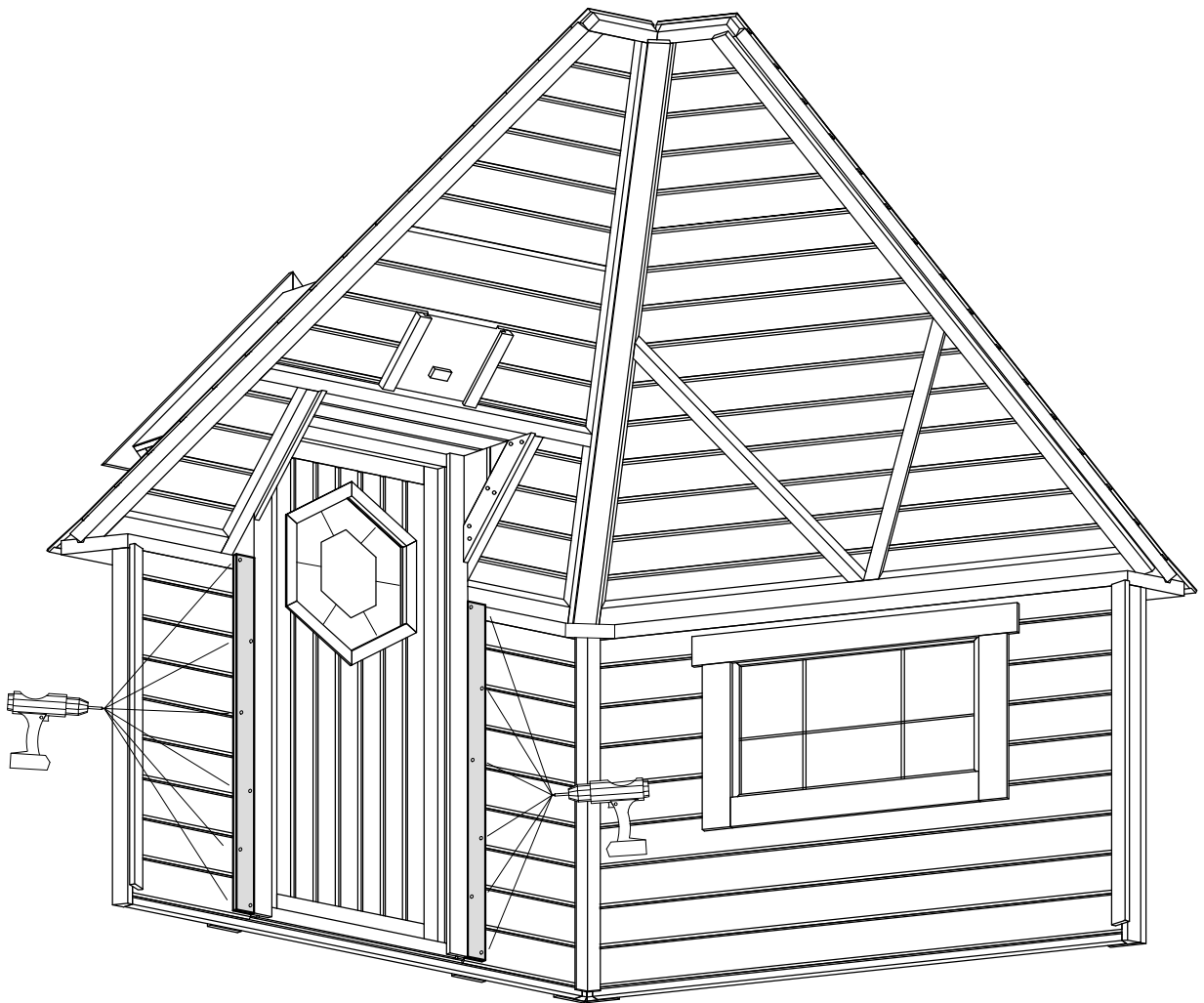

14. Grill cabin 9.2 with sloping walls
INSIDE FINISHING BOARD

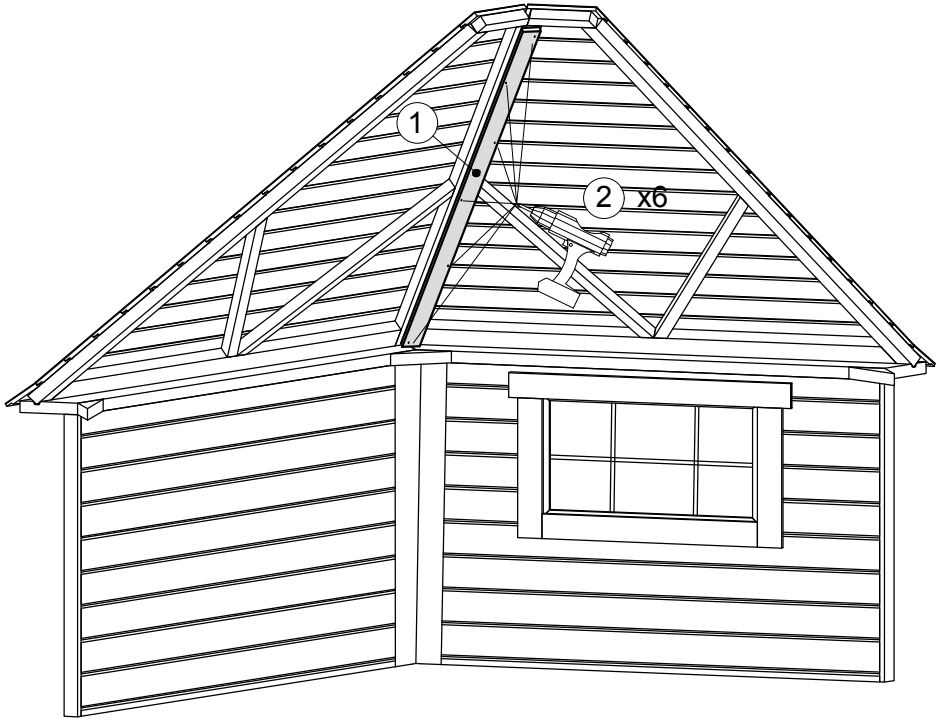
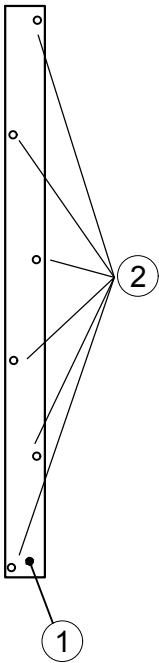
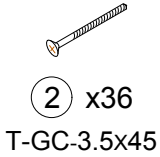
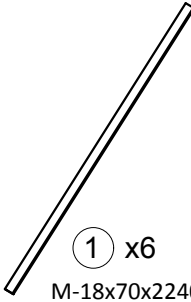
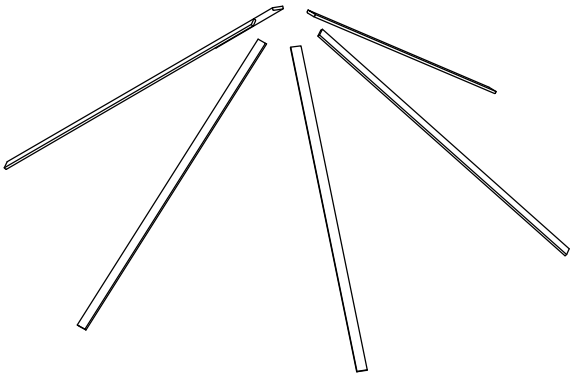

15. Grill cabin 9.2 with sloping walls ASSEMBLY OF BENCHES

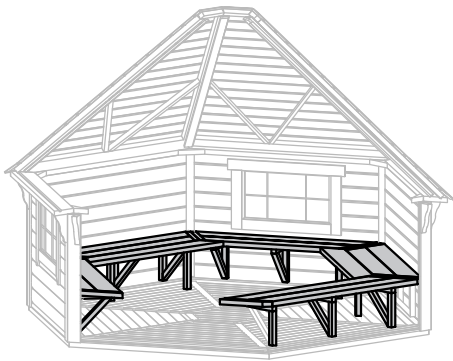

- ① x5
GR9.2-suolai
- ② x2
GR9.2-suolu-praplatinimas
- ③ x15
GR-suolukojos
- ④ x75
T-GC-6x80
- ⑤ x12
T-GC-3x30
- ⑥ x5
M-45x70x1622-F

1 Step

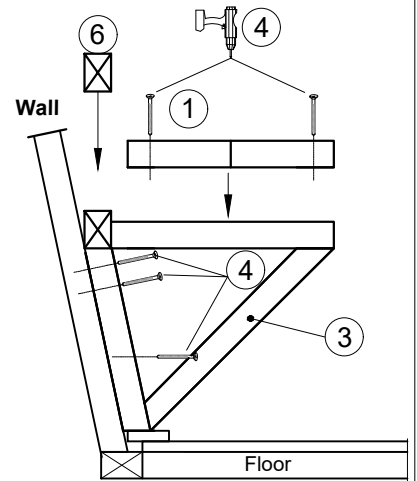
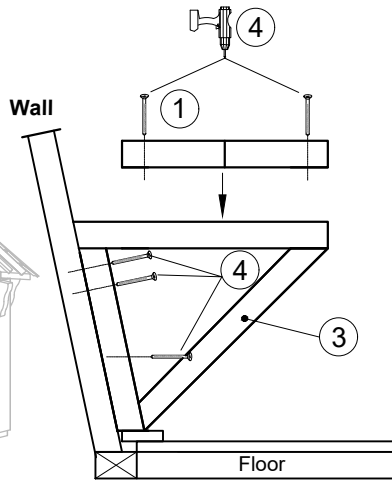
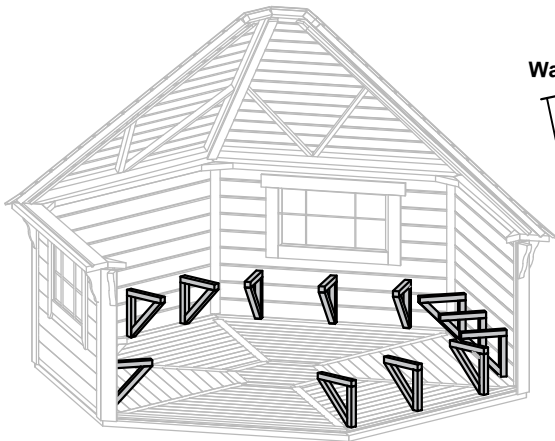

2 Step

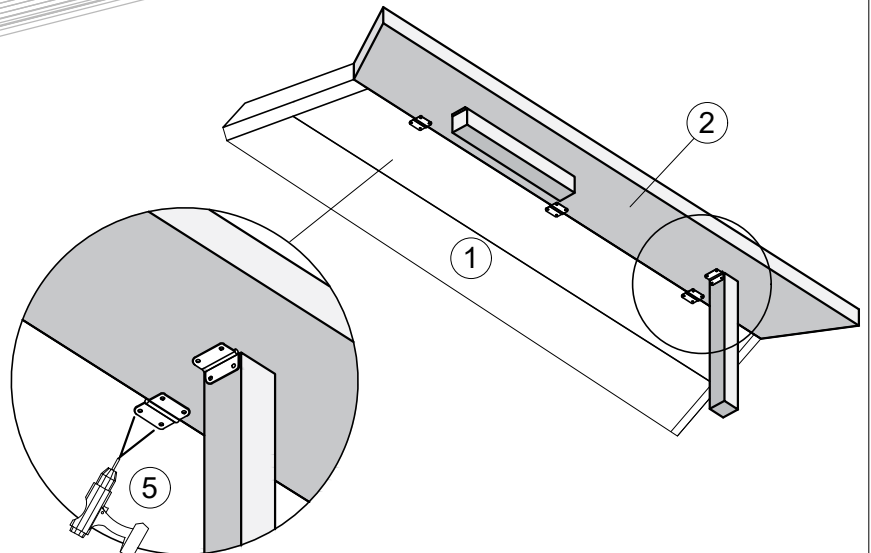
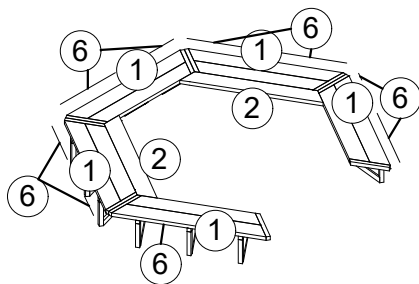
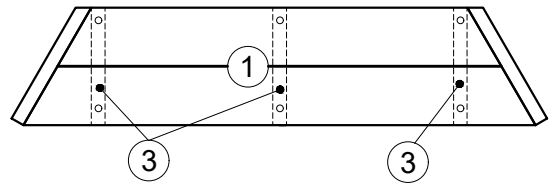
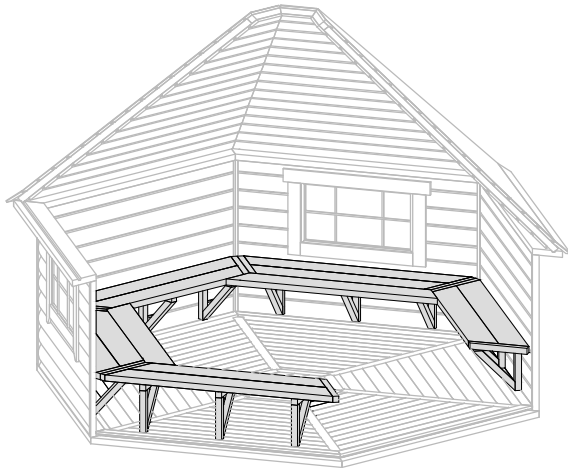

16. Grill cabin 9.2 with sloping walls

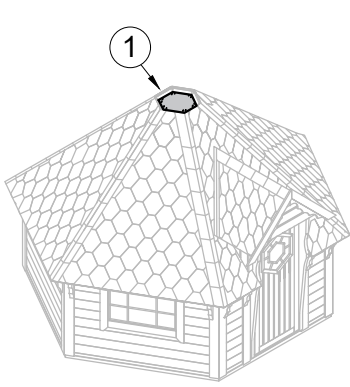

or

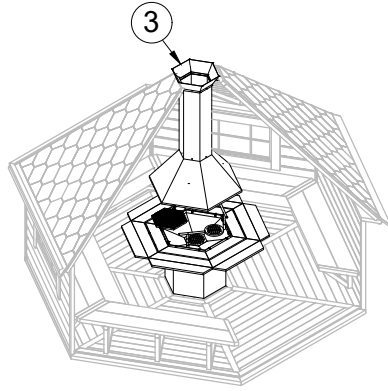

1 x1

GR6k-Stog-dangtis-433x500

or

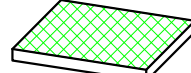

If insulated roof

2 x1

Akmens vata

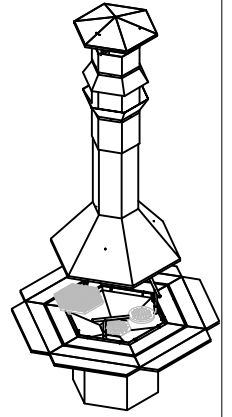

3 x1

GRC06
or
GRCV01
or
GRL06
or
GRP06

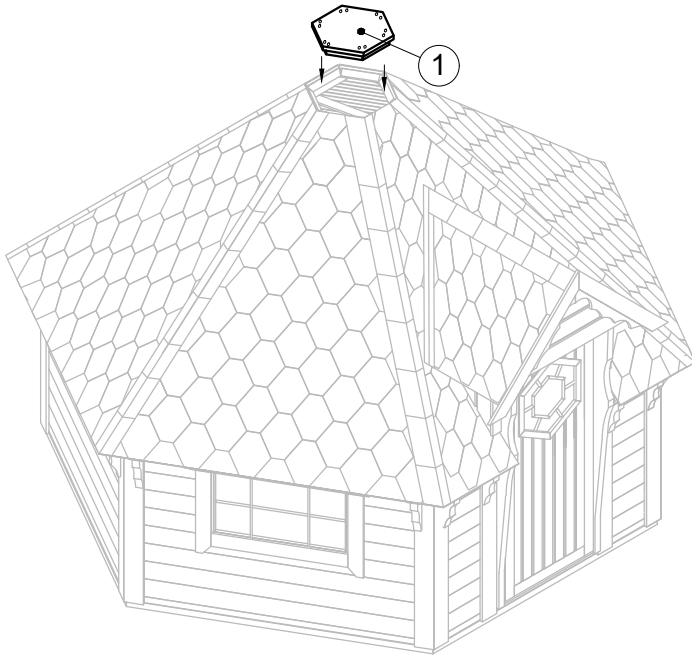

or

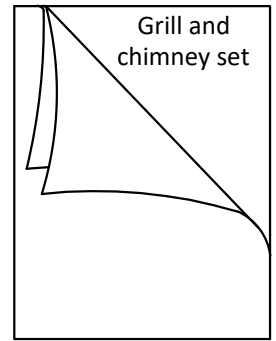
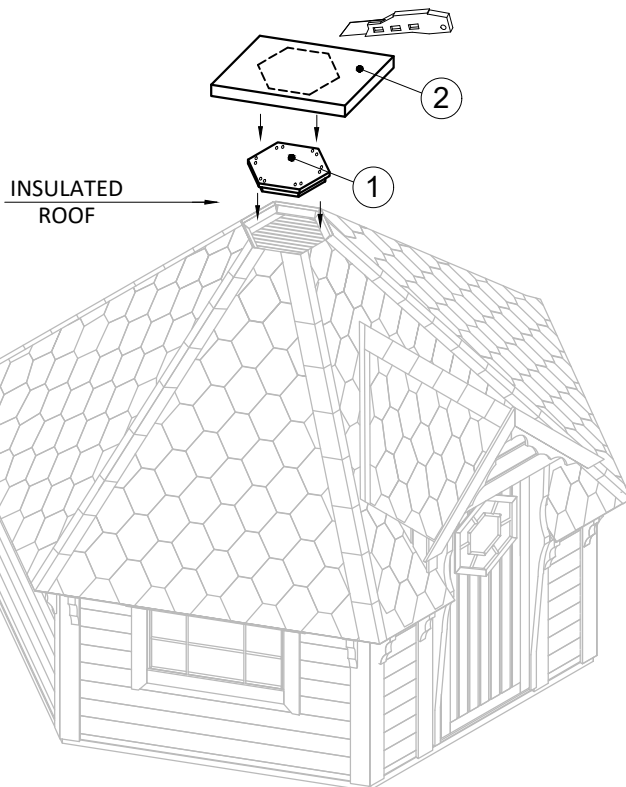

Grill and chimney set

17. Grill cabin 9.2 with sloping walls
ROOF HAT

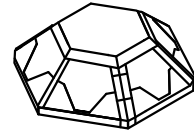
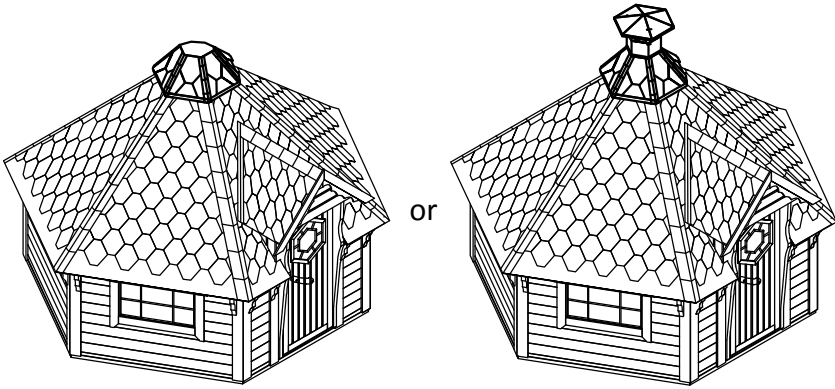

① x1

② x6

GR6k-Kepures-dangtis
or
GR6k-Kepure

T-GC-4x70

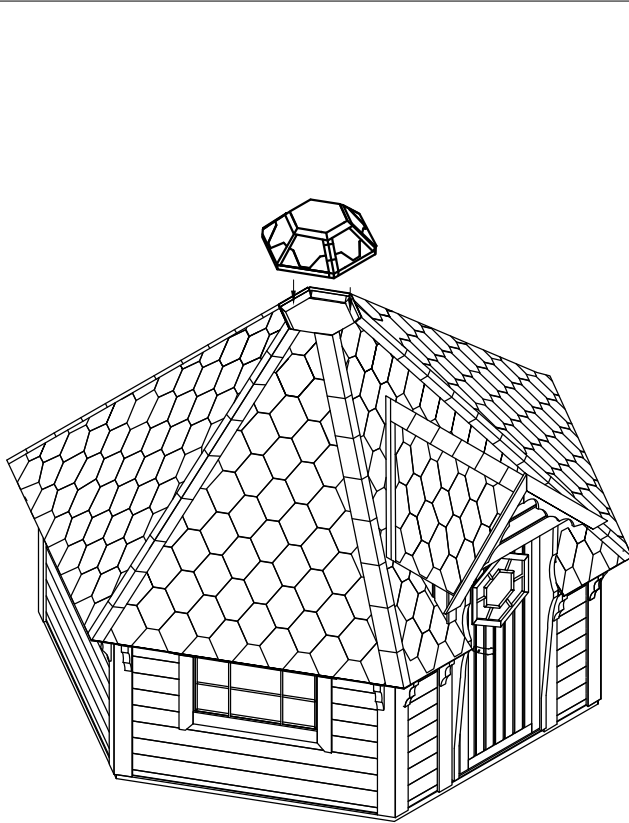

or

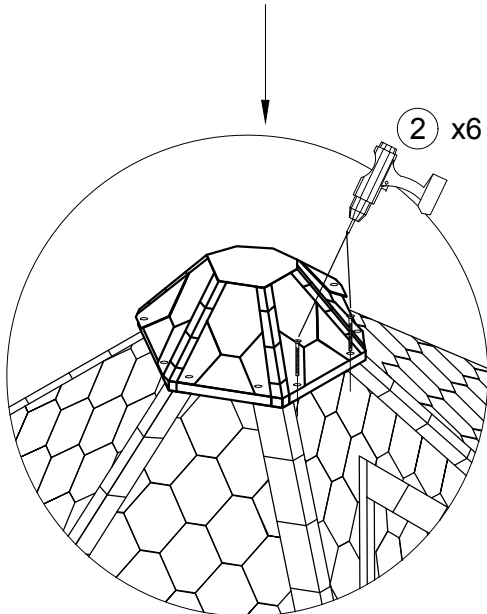
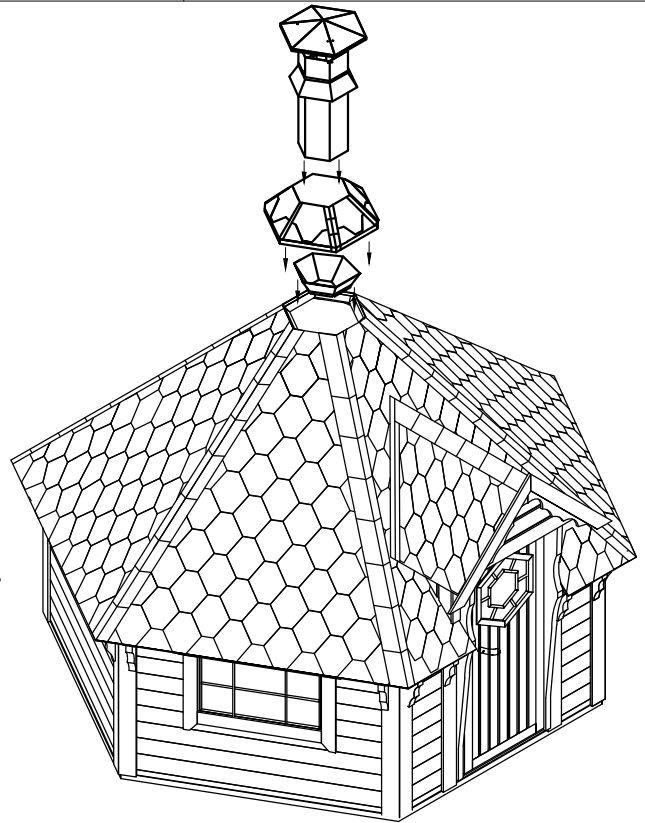

or

